

# BB5005 Danmark



Designed and  
made in Denmark

This model is Copyright protected.  
All Copyrights to this version of the Danmark  
belong to Billing Boats® of 2003 Aps.



260609

## **Skoleskibet DANMARK's historie.**

Den danske stats uddannelsesskib for vordende navigatører. Bygget af stål på Nakskov skibsværft A/S og udleveret i 1933. Hun er forsynet med seks vandtætte skodder, radiotelegraf og en dieselmotor med 250 hestekræfter. Desuden har hun ekkolod og fryserum. Bruttoregister tonnagen er på 777 tons. Dimensioner: Længde 65m, bredde 10m. Skrogets dybde fra dæk 6 m, og hun stikker 4,5 m under vandlinjen. Mandskabet består af: 16 over- og underofficerer, 1 kaptajn, 6 styrmænd, 1 maskinmester, 1 læge, 1 radiotelegrafist, 1 lærer, 1 hovmester, 1 kok, 1 bager, 1 tømmer, 1 sejl-mager og ca. 120 elever. De skal være 15-18 år for at blive elev, og de skal have sejlet i mindst 4 måneder. For ganske få år siden, var 2 års sejlads med søgående sejlskibe en betingelse for, at man kunne erhverve bevis som styrmand. Den eneste mulighed for at undgå dette, var netop skoleskibene. Det samlede togt er på op til 10 måneder. Det deles i to afsnit; Ét om sommeren på ca. 2½ måned, og ét om vinteren på ca. 7 måneder i de sydlige farvande.

## **The history of the Training ship DANMARK.**

This ship is owned by the Danish State and used for the training of navigators. She was built from steel by Nakskov Shipyard and was ready for delivery in 1933. She is equipped with six bulkheads of a watertight type, with wireless telegraph and a diesel engine of 250 HP. Also, she is equipped with an echo sounder and a cold storage. Gross registered tonnage is 777 tons. Dimensions: Length 65 metres, width 10 metres. Depth of hull from deck is 6 metres, and she draws 4,5 metres below the waterline. The crew is made up of 16 officers and petty officers, a captain, 6 mates, an engineer, a doctor, a wireless operator, a teacher, a steward, a cook, a baker, a carpenter, a sail maker, and about 120 trainees. Enrolment age for the trainees is from 15-18, and they must have sailed for at least 4 months. Only a few years ago, 2 years training in sailing vessels was a requirement for the person who wanted to acquire a certificate of competency as mate. The only possibility of fulfilling this requirement was to enrol as a trainee. Each cruise lasts up to 10 months and is divided into two sections, a summer cruise lasting for about 2½ months and a half and a winter cruise lasting for about 7 months and located in the Southern Seas.

## **Die Geschichte des Schulschiffes DANMARK.**

Das Schiff des dänischen Staates zur Ausbildung angehender Navigatoren. Sie ist bei der Nakskov Schiffswerft A/S aus Stahl gebaut und wurde im Jahre 1933 ausgeliefert. Sie ist mit sechs wasserdichten Schotten, mit Funkanlage sowie mit einem 250 PS Dieselmotor versehen. Darüber hinaus hat Sie Echolot und Gefrierräume. Der Schiffsraum beträgt 777 Bruttoregister-tonnen. Größe: Länge 65 m, Breite 10 m. Die Tiefe des Rumpfes vom Deck 6 m und Ihr Tiefgang unter Wasserlinie beträgt 4,5 m. Die Mannschaft besteht aus 16 Offizieren und das Stammpersonal aus Kapitän, 6 ersten Offizieren, 1 Maschinisten, 1 Arzt, 1 Bordfunker, 1 Lehrer, 1 Steward, 1 Koch, 1 Bäcker, 1 Zimmermann, 1 Segelmacher und ca. 120 Schüler. Man muss 15 bis 18 Jahre alt sein, und als Schüler an Bord aufgenommen zu werden und man muss mindestens 4 Monate auf einem Schiff gefahren sein. Noch vor wenigen Jahren war die Erwerbung des Zeugnisses eines ersten Offiziers durch einen 2-jährigen Dienst auf Seegängen Segelschiffen Voraussetzung. Die einzige Möglichkeit zur Erfüllung dieser Forderung waren eben die Schulschiffe. Die gesamte Fahrzeit beträgt 10 Monate, in zwei Abschnitten unterteilt eine ca. 2½ Monate Fahrt im Sommer und einer ca. 7 Monate Fahrt im Winter in den südlichen Gewässern



## **Historique du bateau école 'DANMARK'.**

CE bateau est la propriété de l'Etat Danois. Il est utilisé pour la formation des Marins stagiaires. C'est donc un bateau école. Il a été construit par Nakskov Shipyard et complètement terminé en 1933. Sa conception est basée sur une qualité essentielle: La sécurité. La coque, construite en fer, comporte 6 compartiments étanches. Un moteur auxiliaire diesel de 250 HP équipe le bateau qui comporte également la radio (télégraphie sans fil), un sondeur d'échos et une chambre froide. Tonnage écrit sur registre de mer: 777 tonneaux. Dimensions: Longueur 65 mètres, largeur 10 mètres. Profondeur de la coque, en partant de pont: 6 mètres dont 4,5 mètres au dessus de la ligne de flottaison. L'équipage se compose de 16 officiers et quartiers maitres, 1 capitaine, 6 officiers en second, un ingénieur, un docteur, un opérateur radio, un instructeur, un steward, un cuisinier, un boulanger, un menuisier, un réparateur de voiles et environ 120 stagiaires. L'âge d'engagement pour les stagiaires varie de 15 à 18 ans. Les stagiaires doivent avoir l'expérience de plusieurs mois de navigation avant d'embarquer sur le DANMARK: Il y a seulement quelques années, 2 ans d'école sur un voilier était la condition requise pour qui voulait obtenir le grade de second. La seule possibilité pour y parvenir était de s'engager comme stagiaire. Chaque croisière dure au moins 10 mois et se divise en deux périodes: une croisière d'été durant environ 2½ mois et demi et une croisière d'hiver de 7 mois dans les mers du Sud.

## **Geschiedenis van de DANMARK.**

De Danmark is eigendom van de Deense Staat en wordt gebruikt voor de opleiding van officieren. Zij werd van staal gebouwd op de Nakskov Scheepsverf en werd in 1933 afgeleverd. Zij is uitgerust met 6 waterdichte schotten, radio-telegraaf, echolood, een dieselmotor van 250pk en een vriesruimte. Ze meet 777 BRT. Afmetingen: Lengte 65 m, breedte 10 m, hoogte kiel/dek 6 m, en beneden de waterlijn 4,5 m. De bemanning bestaat uit de kapitein, 16 officieren en onder-officieren, 6 stuurlieden, een machinist, een dokter, een marconist, een leraar, een hofmeester, een kok, een bakker, een timmerman, een zeilmaker, een ongeveer 120 cadetten. De leeftijd van de cadetten loopt van 15-18 jaar en ze moeten tenminste 4 maanden gevaren hebben. Tot voor enige jaren was een 2 jaarlijkse opleiding op een zeilschip noodzakelijk voor die mensen die stuurman wilden worden. De enige mogelijkheid hiertoe was om als cadet in te schrijven. Ledere reis duurt max. 10 maanden en is in tweeden gedeeld, een zomerreis van ca. 2½ maanden en een winterreis van ca. 7 maanden en die door de zuidelijke oceanen voert

## Table of contents for “Danmark”.

| <b>Pcs.</b> | <b>No.</b> | <b>Dimension</b> | <b>Material</b> | <b>Betegnelse</b> | <b>Description</b> | <b>Bezeichnung</b> | <b>Description</b> | <b>Omschrijving</b> |
|-------------|------------|------------------|-----------------|-------------------|--------------------|--------------------|--------------------|---------------------|
| 1A          | 1          | 5 mm             | 3229L           | Køl               | Keel               | Kiel               | Quille             | Kiel                |
| 1B          | 1          | 5 mm             | 3229L           | Agterstævn        | Sternpost          | Achtersteven       | Pièce de proue     | Achtersteven        |
| 1C          | 1          | 5 mm             | 3229L           | Stævn             | Bow                | Vorsteven          | Etrave             | Voorsteven          |
| 2           | 1          | 5 mm             | 3229L           | Spant             | Frame              | Spant              | Couples            | Spanten             |
| 3           | 1          | 5 mm             | 3229L           | Spant             | Frame              | Spant              | Couples            | Spanten             |
| 4           | 1          | 5 mm             | 3229L           | Spant             | Frame              | Spant              | Couples            | Spanten             |
| 5           | 1          | 5 mm             | 3229L           | Spant             | Frame              | Spant              | Couples            | Spanten             |
| 6           | 1          | 5 mm             | 3229L           | Spant             | Frame              | Spant              | Couples            | Spanten             |
| 7           | 1          | 5 mm             | 3229L           | Spant             | Frame              | Spant              | Couples            | Spanten             |
| 8           | 1          | 5 mm             | 3229L           | Spant             | Frame              | Spant              | Couples            | Spanten             |
| 9           | 1          | 5 mm             | 3230L           | Spant             | Frame              | Spant              | Couples            | Spanten             |
| 10          | 1          | 5 mm             | 3230L           | Spant             | Frame              | Spant              | Couples            | Spanten             |
| 11          | 1          | 5 mm             | 3230L           | Spant             | Frame              | Spant              | Couples            | Spanten             |
| 12          | 1          | 5 mm             | 3230L           | Spant             | Frame              | Spant              | Couples            | Spanten             |
| 12A         | 1          | 5 mm             | 3229L           | Bjælkebugt        | Former             | Balkbögen          | Traverses          | Spantdelen          |
| 13          | 1          | 5 mm             | 3230L           | Spant             | Frame              | Spant              | Couples            | Spanten             |
| 14          | 1          | 5 mm             | 3230L           | Spant             | Frame              | Spant              | Couples            | Spanten             |
| 15          | 2          | 5 mm             | 3230L           | Spant             | Frame              | Spant              | Couples            | Spanten             |
| 16          | 2          | 5 mm             | 3230L           | Spant             | Frame              | Spant              | Couples            | Spanten             |
| 17          | 1          | 80 x 42 x 32 mm  |                 | Balsa klods       | Balsa block        | Balsa block        | Bloc Balsa         | Balsa blok          |
| 18          | 1          | 5 mm             | 3230L           | Hjælpeestykke     | Auxiliary piece    | Hilfsstücke        | Pièce annexe       | Hulpstukken         |
| 19          | 1          | 5 mm             | 3230L           | Hjælpeestykke     | Auxiliary piece    | Hilfsstücke        | Pièce annexe       | Hulpstukken         |
| 20          | 1          | 5 mm             | 3230L           | Skot              | Bulkhead           | Schott             | Pont               | Schot               |
| 20A         | 1          | 2 mm             | 3233L           | Skot/agter        | Bulkhead/aft       | Schott/achter      | Pont/arrière       | Schot/achter        |
| 21          | 1          | 5 mm             | 3229L           | Hjælpeestykke     | Auxiliary piece    | Hilfsstücke        | Pièce annexe       | Hulpstukken         |
| 22          | 2          | 2 mm             | 3232L           | Hjælpeestykke     | Auxiliary piece    | Hilfsstücke        | Pièce annexe       | Hulpstukken         |
| 23          | 1          | 2 mm             | 3232L           | Hoveddæk          | Deck               | Deck               | Pont               | Dek                 |
| 24          | 1          | 2 mm             | 3232L           | Dæk/agter         | Deck/aft           | Deck/Achter        | Pont/arrière       | Dek/achter          |
| 25          | 1          | 14 x 20 x 30 mm  |                 | Klods             | Block              | Klotz              | Poulie             | Blok                |
| 26          | 2          | 2 mm             | 3233L           | Skot/stævn        | Bulkhead/stern     | Schott/vorsteven   | Pont/étrave        | Schot/voorsteven    |
| 27          | 2          | 2 mm             | 3233L           | Skot/stævn        | Bulkhead/stern     | Schott/vorsteven   | Pont/étrave        | Schot/voorsteven    |
| 28          | 1          | 2 mm             | 3233L           | Dæk/stævn         | Deck/stem          | Deck/Vorsteven     | Pont/étrave        | Dek/voor            |
| 29          | 1          | 2 mm             | 3233L           | Skot/stævn        | Bulkhead/bow       | Schott/Vorsteven   | Pont/étrave        | Schot/voorsteven    |
| 30          | 2          | 2 mm             | 3233L           | Dørk/stævn        | Floor/stern        | Gräting/Vorschiff  | Parquet/étrave     | Gräting/voorsteven  |
| 31          | 2          | 2 mm             | 3235L           | Faconbeklædning   | Formed piece       | Formteil           | Pièce préfabriquée | Gevormd deel        |
| 31A         | 2          | 2 mm             | 3234L           | Faconbeklædning   | Formed piece       | Formteil           | Pièce préfabriquée | Gevormd deel        |
| 32          | 2          | 2 mm             | 3232L           | Faconbeklædning   | Formed piece       | Formteil           | Pièce préfabriquée | Gevormd deel        |
| 33          | 1          | 2 mm             | 3236L           | Faconbeklædning   | Formed piece       | Formteil           | Pièce préfabriquée | Gevormd deel        |
| 34          | 1          | 2 mm             | 3232L           | Faconbeklædning   | Formed piece       | Formteil           | Pièce préfabriquée | Gevormd deel        |
| 34 A        | 1          | 2 mm             | 3232L           | Faconbeklædning   | Formed piece       | Formteil           | Pièce préfabriquée | Gevormd deel        |
| 35          | 42         | 1,8 x 7 x 780 mm |                 | Liste/beklædning  | Strip/planking     | Leiste/Beplankung  | Babuettes/bordage  | Strips/beplanking   |
| 36 A        | 2          | 5 mm             | 3230L           | Bedding           | Slip               | Helling            | Cale               | Standaard           |
| 36 B        | 2          | 5 mm             | 3230L           | Bedding           | Slip               | Helling            | Cale               | Standaard           |
| 37 A        | 2          | 5 mm             | 3237 L          | Bedding           | Slip               | Helling            | Cale               | Standaard           |
| 37 B        | 2          | 5 mm             | 3229L           | Bedding           | Slip               | Helling            | Cale               | Standaard           |
| 38          | 1          | 5 mm             | 3229L           | Ror               | Rudder             | Ruder              | Gouvernail         | Roer                |

| <b>Pcs.</b> | <b>No.</b> | <b>Dimension</b> | <b>Material</b> | <b>Betegnelse</b>    | <b>Description</b> | <b>Bezeichnung</b>    | <b>Description</b>          | <b>Omschrijving</b>  |
|-------------|------------|------------------|-----------------|----------------------|--------------------|-----------------------|-----------------------------|----------------------|
| 38 A        | 4          | 2 mm             | 3232L           | Rorhængsel           | Rudder suspension  | Ruderbeschlag         | Charnière de gouvernail     | Roerophanging        |
| 39          | 2          | 1,8 x 2 x 550 mm |                 | Liste                | Strip              | Leiste                | Baguette                    | Strip                |
| 40          | 7          | 0,7 x 2 x 550 mm |                 | Liste                | Strip              | Leiste                | Baguette                    | Strip                |
| 41          | 94         | 0,7 x 3 x 550 mm |                 | Liste                | Strip              | Leiste                | Baguette                    | Strip                |
| 42          | 2          | 2 mm             | 3232L           | Naglebænk            | Pin bench          | Nägelbank             | Râtelier                    | Nagelbank            |
| 43          | 1          | 2 mm             | 3232L           | Naglebænk            | Pin bench          | Nägelbank             | Râtelier                    | Nagelbank            |
| 44          | 2          | 2 mm             | 3232L           | Naglebænk            | Pin bench          | Nägelbank             | Râtelier                    | Nagelbank            |
| 45          | 2          | 2 mm             | 3232L           | Naglebænk            | Pin bench          | Nägelbank             | Râtelier                    | Nagelbank            |
| 46          | 2          | 2 mm             | 3232L           | Naglebænk            | Pin bench          | Nägelbank             | Râtelier                    | Nagelbank            |
| 47          | 1          | 2 mm             | 3232L           | Naglebænk            | Pin bench          | Nägelbank             | Râtelier                    | Nagelbank            |
| 48          | 1          | 10 x 38 x 12 mm  |                 | Klods                | Block              | Klotz                 | Poulie                      | Blok                 |
| 49          | 1          | 28 x 31 x 13 mm  |                 | Klods                | Block              | Klotz                 | Poulie                      | Blok                 |
| 50          | 2          | 6 x 8 x 7 mm     |                 | Klods                | Block              | Klotz                 | Poulie                      | Blok                 |
| 51          | 2          | 2 mm             | 3233L           | Kahyt/ende           | Cabin/end          | Kajüte/ende           | Cabine/bout                 | Kajuit/eind          |
| 52          | 1          | 2 mm             | 3233L           | Kahyt/side           | Cabin/side         | Kajüte/Seite          | Cabine/côté                 | Kajuit/zijde         |
| 53          | 1          | 2 mm             | 3233L           | Kahyt/side           | Cabin/side         | Kajüte/Seite          | Cabine/côté                 | Kajuit/zijde         |
| 54          | 1          | 2 mm             | 3233L           | Kahyt/tag            | Cabin/roof         | Kajüte/Dach           | Cabine/toit                 | Kajuit/dak           |
| 55          | 1          | 12 x 16 x 14 mm  |                 | Klods                | Block              | Klotz                 | Poulie                      | Blok                 |
| 56          | 1          | 2 mm             | 3233L           | Kasse/låg            | Box/cover          | Kasten/Deckel         | Caisse/couvercle            | Kist/deksel          |
| 57          | 1          | 20 x 25 x 21 mm  |                 | Klods                | Block              | Klotz                 | Poulie                      | Blok                 |
| 58          | 1          | 2 mm             | 3233L           | Nedgang/tag          | Companion/roof     | Niedergang/Dach       | Ecoutille avant/toit        | Trapafgang/dak       |
| 59          | 1          | 2 mm             | 3233L           | Nedgang/luge         | Companion/hatch    | Niedergang/Luke       | Ecoutille                   | Trapafgang/luik      |
| 60          | 2          | 7 x 7 x 15 mm    |                 | Klods                | Block              | Klotz                 | Poulie                      | Blok                 |
| 61          | 1          | 2 mm             | 3233L           | Kahyt/side           | Cabin/side         | Kajüte/Seite          | Cabine/côté                 | Kajuit/zijde         |
| 62          | 1          | 2 mm             | 3232L           | Kahyt/ende           | Cabin/end          | Kajüte/Ende           | Cabine/bout                 | Kajuit/eind          |
| 63          | 1          | 2 mm             | 3233L           | Kahyt/ende           | Cabin/end          | Kajüte/Ende           | Cabine/bout                 | Kajuit/eind          |
| 64          | 1          | 2 mm             | 3233L           | Kahyt/tag            | Cabin/roof         | Kajüte/Dach           | Cabine/toit                 | Kajuit/dak           |
| 65          | 1          | 8 x 33 x 12 mm   |                 | Klods                | Block              | Klotz                 | Poulie                      | Blok                 |
| 66          | 1          | 16 x 25 x 11 mm  |                 | Klods                | Block              | Klotz                 | Poulie                      | Blok                 |
| 67          | 1          | 12 x 14 x 6 mm   |                 | Klods                | Block              | Klotz                 | Poulie                      | Blok                 |
| 68          | 2          | 2 mm             | 3232L           | Kahyt/side           | Cabin/side         | Kajüte/Seite          | Cabine/côté                 | Kajuit/zijde         |
| 69          | 1          | 2 mm             | 3233L           | Kahyt/ende           | Cabin/end          | Kajüte/Ende           | Cabine/bout                 | Kajuit/eind          |
| 70          | 1          | 2 mm             | 3233L           | Kahyt/ende           | Cabin/end          | Kajüte/Ende           | Cabine/bout                 | Kajuit/eind          |
| 71          | 1          | 2 mm             | 3233L           | Kahyt/tag            | Cabin/roof         | Kajüte/Dach           | Cabine/toit                 | Kajuit/dak           |
| 72          | 1          | 5 x 10 x 19 mm   |                 | Klods                | Block              | Klotz                 | Poulie                      | Blok                 |
| 73          | 2          | 2 mm             | 3233L           | Bro/bund             | Bridge/bottom      | Komm.brücke/boden     | Passerelle/fond             | Comm.brug/bodem      |
| 74          | 2          | 2 mm             | 3233L           | Bro/side             | Bridge/side        | Komm.brücke/seite     | Passerelle/côté             | Comm.brug/zijde      |
| 75          | 2          | 2 mm             | 3233L           | Bro/side             | Bridge/side        | Komm.brücke/seite     | Passerelle/côté             | Comm.brug/zijde      |
| 76          | 2          | 2 mm             | 3233L           | Bro/side             | Bridge/side        | Komm.brücke/seite     | Passerelle/côté             | Comm.brug/zijde      |
| 77          | 2          | 2 mm             | 3233L           | Bro/side             | Bridge/side        | Komm.brücke/seite     | Passerelle/côté             | Comm.brug/zijde      |
| 78          | 2          | 2 mm             | 3233L           | Bro/side             | Bridge/side        | Komm.brücke/seite     | Passerelle/côté             | Comm.brug/zijde      |
| 79          | 1          | 2 mm             | 3233L           | Gelænder             | Rail               | Geländer              | Bastingage                  | Railing              |
| 80          | 1          | 2 mm             | 3233L           | Gelænder             | Rail               | Geländer              | Bastingage                  | Railing              |
| 81          | 2          | 2 mm             | 3233L           | Gelænder             | Rail               | Geländer              | Bastingage                  | Railing              |
| 82          | 12         | 2 mm             | 3232L           | Redningsflåde/holder | Liferaft/support   | Rettungsinsel/stützen | Radeau de sauvetage/support | Reddingsvlot/steunen |
| 83          | 1          | 2 mm             | 3233L           | Overdæk              | Upperdeck          | Oberdeck              | Pont supérieur              | Bovendek             |
| 84          | 1          | 2 mm             | 3233L           | Støtte               | Support            | Stützen               | Support                     | Steunen              |
| 85          | 2          | 2 mm             | 3232L           | Støtte               | Support            | Stützen               | Support                     | Steunen              |

| <b>Pcs.</b> | <b>No.</b> | <b>Dimension</b> | <b>Material</b> | <b>Betegnelse</b>    | <b>Description</b> | <b>Bezeichnung</b>    | <b>Description</b>          | <b>Omschrijving</b>  |
|-------------|------------|------------------|-----------------|----------------------|--------------------|-----------------------|-----------------------------|----------------------|
| 86          | 2          | 8 x 8 x 58mm     |                 | Skorsten             | Funnel             | Schornstein           | Cheminée                    | Schoorsteen          |
| 87          | 1          | 2 mm             | 3233L           | Skorsten/top         | Funnel/top         | Schornstein/Top       | Cheminée/Haut               | Schoorsteen/Top      |
| 88 A        | 2          | 2 mm             | 3233L           | Overdæk              | Upperdeck          | Oberdeck              | Pont supérieur              | Bovendek             |
| 88 B        | 2          | 2 mm             | 3233L           | Overdæk              | Upperdeck          | Oberdeck              | Pont supérieur              | Bovendek             |
| 89          | 4          | 2 mm             | 3232L           | Støtte               | Support            | Stützen               | Support                     | Steunen              |
| 90          | 6          | 2 mm             | 3232L           | Redningsflåde/holder | Liferaft/support   | Rettungsinsel/stützen | Radeau de sauvetage/support | Reddingsvlot/steunen |
| 91          | 1          | 13 x 13 x 7 mm   |                 | Klods                | Block              | Klotz                 | Poulie                      | Blok                 |
| 92          | 1          | 2 mm             | 3233L           | Luge                 | Hatch              | Luke                  | Ecoutille                   | Luik                 |
| 93          | 1          | 4 x 4 x 300 mm   |                 | Liste                | Strip              | Leiste                | Baguette                    | Strip                |
| 94          | 1          | Ø2 x 155 mm      |                 | Rundstok             | Round stick        | Rundstab              | Baguette ronde              | Rondhout             |
| 96          | 2          | 2 mm             | 3232L           | Liste/ræling         | Strips/rail        | Leiste/Reling         | Baguette/bastingage         | Strip/reling         |
| M 0         | 1          | 4,5 x 140 mm     |                 | Mast                 | Masts              | Masten                | Mâts                        | Masten               |
| M 1         | 2          | 4,5 x 180 mm     |                 | Mast                 | Masts              | Masten                | Mâts                        | Masten               |
| M 2         | 1          | 5,5 x 240 mm     |                 | Mast                 | Masts              | Masten                | Mâts                        | Masten               |
| M 3         | 2          | 6,5 x 180 mm     |                 | Mast                 | Masts              | Masten                | Mâts                        | Masten               |
| M 4         | 2          | 6,5 x 235 mm     |                 | Mast                 | Masts              | Masten                | Mâts                        | Masten               |
| M 6         | 2          | 8,5 x 260 mm     |                 | Mast                 | Masts              | Masten                | Mâts                        | Masten               |
| R 0         | 1          | Ø3 x 120mm       |                 | Ræer                 | Stays              | Rahen                 | Vergues                     | Stengen              |
| R 1         | 6          | Ø3 x 140mm       |                 | Ræer                 | Stays              | Rahen                 | Vergues                     | Stengen              |
| R 2         | 1          | Ø4 x 180mm       |                 | Ræer                 | Stays              | Rahen                 | Vergues                     | Stengen              |
| R 3         | 4          | Ø4 x 180mm       |                 | Ræer                 | Stays              | Rahen                 | Vergues                     | Stengen              |
| R 4         | 1          | Ø4 x 225mm       |                 | Ræer                 | Stays              | Rahen                 | Vergues                     | Stengen              |
| R 5         | 3          | Ø4 x 225mm       |                 | Ræer                 | Stays              | Rahen                 | Vergues                     | Stengen              |
| R 6         | 2          | Ø5 x 250mm       |                 | Ræer                 | Stays              | Rahen                 | Vergues                     | Stengen              |
| R 7         | 2          | Ø5 x 280mm       |                 | Ræer                 | Stays              | Rahen                 | Vergues                     | Stengen              |
| 98 A        | 2          | 2 mm             | 3232L           | Mærs                 | Top                | Mars                  | Hune                        | Top                  |
| 98 B        | 2          | 2 mm             | 3232L           | Mærs                 | Top                | Mars                  | Hune                        | Top                  |
| 98 C        | 2          | 2 mm             | 3232L           | Mærs                 | Top                | Mars                  | Hune                        | Top                  |
| 98 D        | 2          | 2 mm             | 3232L           | Mærs                 | Top                | Mars                  | Hune                        | Top                  |
| 99 A        | 1          | 2 mm             | 3232L           | Mærs                 | Top                | Mars                  | Hune                        | Top                  |
| 99 B        | 1          | 2 mm             | 3232L           | Mærs                 | Top                | Mars                  | Hune                        | Top                  |
| 99 C        | 2          | 2 mm             | 3232L           | Mærs                 | Top                | Mars                  | Hune                        | Top                  |
| 99 D        | 2          | 2 mm             | 3232L           | Mærs                 | Top                | Mars                  | Hune                        | Top                  |
| 100         | 2          | 2 mm             | 3232L           | Motorbåd/støtte      | Motorboat/Support  | Motorboot/Stützen     | Canot à moteur/Support      | Motorboot/Steunen    |
| 101         | 2          | 2 mm             | 3232L           | Kran/beslag          | Crane/Fitting      | Kran/Beschlag         | Grue/Garniture              | Kraan/beslag         |
| 102         | 10         | 2 mm             | 3232L           | Kran/beslag          | Crane/Fitting      | Kran/Beschlag         | Grue/Garniture              | Kraan/beslag         |
| 103         | 2          | 2 mm             | 3232L           | Kran                 | Crane              | Kran                  | Grue                        | Kraan                |
| 104         | 2          | 2 mm             | 3232L           | Gummibåd/støtte      | Rubberboat/Support | Schlauchboot/Stützen  | Canot pneumatque/Support    | Rubberboot/Steunen   |
| 105         | 1          | 2 mm             | 3232L           | Svingkran            | Slewing crane      | Schwingkran           | Grue tournante              | Draaikraan           |
| 106         | 1          | 2 mm             | 3232L           | Svingkran, skive     | Slewing crane/Disc | Schwingkran/Scheibe   | Grue tournante/Tranche      | Draaikraan/Sneetje   |
| 107         | 1          | Ø6 x 150 mm      |                 | Rundstok             | Round stick        | Rundstab              | Baguette ronde              | Rondhout             |
| 108         | 1          | 2 mm             | 3232L           | Gummibåd/bund        | Rubberboat/Bottom  | Schlauchboot/Boden    | Canot pneumatque/Bas        | Rubberboot/Onderkant |
| 109         | 1          | 5 mm             | 3229L           | Gummibåd/top         | Rubberboat/Top     | Schlauchboot/Top      | Canot pneumatque/Haut       | Rubberboot/Top       |
| 110         | 2          | 2 mm             | 3232L           | Gummibåd/motor       | Rubberboat/Engine  | Schlauchboot/Motor    | Canot pneumatque/Moteur     | Rubberboot/Motor     |
| 111         | 1          | 1 mm             | 3231L           | Motorbåd/dæk         | Motorboat/Deck     | Motorboot/Deck        | Canot à moteur/Deck         | Motorboot/Dek        |
| 112         | 2          | 1 mm             | 3231L           | Vinduesrammer        | Window frames      | Fensterrahmen         | Encadrements de fenetres    | Raamlijsten          |
| 113         | 2          | 1 mm             | 3231L           | Vinduesrammer        | Window frames      | Fensterrahmen         | Encadrements de fenetres    | Raamlijsten          |
| 114         | 1          | 1 mm             | 3231L           | Vinduesrammer        | Window frames      | Fensterrahmen         | Encadrements de fenetres    | Raamlijsten          |

| <b>Pcs.</b> | <b>No.</b> | <b>Dimension</b> | <b>Material</b> | <b>Betegnelse</b> | <b>Description</b>    | <b>Bezeichnung</b> | <b>Description</b>       | <b>Omschrijving</b>      |
|-------------|------------|------------------|-----------------|-------------------|-----------------------|--------------------|--------------------------|--------------------------|
| 115         | 1          | 1 mm             | 3231L           | Kant              | Edge                  | Kante              | Bord                     | Rand                     |
| 116         | 2          | 1 mm             | 3231L           | Stige             | Ladder                | Leiter             | Échelle                  | Ladder                   |
| 117         | 2          | 2 mm             | 3233L           | Kasse             | Box                   | Kasten             | Caisse                   | Kist                     |
| 118         | 2          | 6 x 8 x 60 mm    |                 | Kasse             | Box                   | Kasten             | Caisse                   | Kist                     |
| 119         | 2          | 5 x 6 x 55 mm    |                 | Kasse             | Box                   | Kasten             | Caisse                   | Kist                     |
| 120         | 1          | Ø2 x 49 mm       |                 | Messingrør        | Brass tube            | Messingrohr        | Tube de laiton           | Messingbuis              |
| 121         | 6          | 6 x 6 x 10mm     |                 | Ventil/top        | Vent/top              | Lüfter/top         | Manche á air/tête        | Luchtkoker/top           |
| 122         | 2          | Ø3 x 12mm        |                 | Ventil/sokkel     | Vent/tube             | Lüfter/rohr        | Manche á air/tube        | Luchtkoker/buis          |
| 123         | 2          | Ø5 x 4mm         |                 | Ventil/top        | Vent/top              | Lüfter/top         | Manche á air/tête        | Luchtkoker/top           |
| 124         | 1          |                  |                 | Acetat            | Acetate               | Azetat             | Rhodoit                  | Acetaat                  |
| 125         | 4          | Ø4 x 35mm        |                 | Ventil/sokkel     | Vent/tube             | Lüfter/rohr        | Manche á air/tube        | Luchtkoker/buis          |
| F001        | 2          |                  |                 | Lanterne          | Lantern               | Lanterne           | Lanterne                 | Boordlichten             |
| F017        | 2          |                  |                 | Bombeslag         | Barfitting            | Baumbeschlag       | Garniture de bôme        | Lummel                   |
| F021        | 97         |                  |                 | Vantskrue         | Turnshoud             | Wantschrauben      | Rodoirs                  | Wantspanners             |
| F022        | 1          | Ø0,3 x 2500mm    |                 | Kobbertråd        | Copperwire            | Kupferdraht        | Fil de cuivre            | Koperdraad               |
| F22A        | 1          | Ø0,5 x 2500mm    |                 | Kobbertråd        | Copperwire            | Kupferdraht        | Fil de cuivre            | Koperdraad               |
| F028        | 2          |                  |                 | Ventil            | Vent                  | Lüfter             | Manche á air             | Luchtkok                 |
| F039        | 10         | Ø1x250mm         |                 | Messingtråd       | Brasswire             | Messingdraht       | Fil de laiton            | Messingdraad             |
| F041        | 6          |                  |                 | Klyds             | Fairlead              | Verholklüse        | Chaumard                 | Verhaalklamp             |
| F045        | 1          |                  |                 | Skrue             | Propeller             | Schiffsschraube    | Arbre porte-hélice       | Schoef                   |
| F051        | 3          |                  |                 | Rat               | Wheel                 | Steuerrad          | Roue                     | Stuurwiel                |
| F054        | 136        |                  |                 | Kofilnagel        | Belaying pin          | Belegnägel         | Cabillots                | Korvijnagel              |
| F056        | 2          |                  |                 | Klokke            | Bell                  | Glocke             | Cloche                   | Scheepsbel               |
| F057        | 3          |                  |                 | Anker             | Anchor                | Anker              | Ancre                    | Anker                    |
| F058        | 1 set      |                  |                 | Galionsfigur      | Figurehead            | Galionsfigur       | Figure de proue          | Boegbeeld                |
| F059        | 1          |                  |                 | Nathus            | Binnacle              | Kompasshaus        | Habitacle                | Kompashuis               |
| F061        | 1          |                  |                 | Svingkran         | Crane                 | Kran               | Grue                     | Kraan                    |
| F068        | 1          |                  |                 | Maskintelegraf    | Engine room telegraph | Maschinentelegraph | Commande de machine      | Machinekamertelegraaf    |
| F070        | 1          | 150 m            |                 | Rigningstråd      | Rigging thread        | Takelgarn          | Fil de gréement          | Takelgaren               |
| F071        | 1          | 75 m             |                 | Rigningstråd      | Rigging thread        | Takelgarn          | Fil de gréement          | Takelgaren               |
| F076        | 1          | 78cm             |                 | Ankerkæde         | Anchor chain          | Anker kette        | Chaine                   | Ketting                  |
| F100        | 1          |                  |                 | Lanterne          | Lantern               | Lanterne           | Lanterne                 | Boordlichten             |
| F106        | 23         |                  |                 | Pullert           | Bollard               | Poller             | Bitte                    | Bolder                   |
| F136        | 6          |                  |                 | Redningsbælte     | Lifebelt              | Retningsring       | Ceintures de sauvetage   | Reddingsgordel           |
| F145        | 100        |                  |                 | Gelænderstøtte    | Railstanchions        | Relingstützen      | Chandeliers              | Railingpalen             |
| F168        | 2          |                  |                 | Redningsbåd       | Lifeboat              | Retningsboot       | Chaloupe ponte           | Reddingsboot             |
| F181        | 5          |                  |                 | Lejder            | Ladder                | Leiter             | Echelle                  | Ladder                   |
| F190        | 2          |                  |                 | Ankerklyds        | Anchor fairlead       | Ankerscheibgatt    | Ecubier de l'ancre       | Verhaalklamp             |
| F230        | 20         |                  |                 | Søm               | Pins                  | Nägel              | Clous                    | Spijkertjes              |
| F233        | 1          |                  |                 | Redningsbåd       | Lifeboat              | Retningsboot       | Chaloupe ponte           | Reddingsboot             |
| F272        | 1          |                  |                 | Spil              | Winch                 | Winde              | Treuil                   | Winch                    |
| F274        | 1          |                  |                 | Bovsprydbeslag    | Cap w/ martingale     | Bugsprieteselhaupt | Sous barbe de martingale | Ezelshoofd m. sp. Ruiter |
| F285        | 16         |                  |                 | Øjebolt           | Eyebolt               | Augenbolzen        | Pitons                   | Oogbouten                |
| F317        | 14         |                  |                 | Køje              | Portlight             | Bullaugen          | Hublots                  | Patrijspoot              |
| F327        | 1          | 50cm             |                 | Ankerkæde         | Anchor chain          | Anker kette        | Chaine                   | Ketting                  |
| F330        | 2          |                  |                 | Søm               | Pins                  | Nägel              | Clous                    | Spijkertjes              |
| F348        | 2          |                  |                 | Klampe            | Cleats                | Klampen            | Taquets                  | Kikkers                  |
| F374        | 2          |                  |                 | Rulle             | Reel                  | Rollen             | Dévidoirs                | Rollen                   |

| <b>Pcs.</b> | <b>No.</b> | <b>Dimension</b> | <b>Material</b> | <b>Betegnels</b> | <b>Description</b> | <b>Bezeichnung</b> | <b>Description</b>   | <b>Omschrijving</b> |
|-------------|------------|------------------|-----------------|------------------|--------------------|--------------------|----------------------|---------------------|
| F375        | 4          |                  |                 | Rulle            | Reel               | Rollen             | Dévidoirs            | Rollen              |
| F376        | 2          |                  |                 | Wirerulle        | Wire reel          | Wire rolle         | Devidoir             | Katrol              |
| F378        | 3          |                  |                 | Mastetop         | Masthead           | Masttop            | Tête de mât          | Masttop             |
| F444        | 2          |                  |                 | Kapstan          | Capstan            | Kapstan            | Cabestan             | Gangspil            |
| F447        | 35         |                  |                 | Vantskrue        | Turnshoud          | Wantschrauben      | Rodoirs              | Wantspanners        |
| F498        | 15         |                  |                 | Råbeslag         | Yard fitting       | Beschalg für Rahe  | Garniture de vergues | Rabeslag            |
| F499        | 6          |                  |                 | Råbeslag         | Yard fitting       | Beschalg für Rahe  | Garniture de vergues | Rabeslag            |
| F501        | 9          |                  |                 | Ring             | Hoop               | Ring               | Cercle               | Ring                |
| F502        | 26         |                  |                 | Ring             | Hoop               | Ring               | Cercle               | Ring                |
| F503        | 13         |                  |                 | Ring             | Hoop               | Ring               | Cercle               | Ring                |
| F504        | 1          |                  |                 | Ring             | Hoop               | Ring               | Cercle               | Ring                |
| F511        | 4          |                  |                 | David            | Davit              | Davit              | Bossoir              | Davit               |
| F514        | 2          |                  |                 | David            | Davit              | Davit              | Bossoir              | Davit               |
| F527        | 1          |                  |                 | Mastebeslag      | Mast fitting       | Mastbeschlag       | Garniture de mât     | Mastbeslag          |
| F528        | 1          |                  |                 | Mastebeslag      | Mast fitting       | Mastbeschlag       | Garniture de mât     | Mastbeslag          |
| F529        | 2          |                  |                 | Mastebeslag      | Mast fitting       | Mastbeschlag       | Garniture de mât     | Mastbeslag          |
| F530        | 4          |                  |                 | Mastebeslag      | Mast fitting       | Mastbeschlag       | Garniture de mât     | Mastbeslag          |
| F531        | 3          |                  |                 | Mastebeslag      | Mast fitting       | Mastbeschlag       | Garniture de mât     | Mastbeslag          |
| F537        | 86         |                  |                 | Røstjern         | Chain plate        | Putting            | Cadene               | Putting             |
| F546        | 10         |                  |                 | Pullert/underlag | Bollard/support    | Poller/Unterlag    | Bitte/socle          | Bolder/console      |
| F547        | 1          | Ø3x250mm         |                 | Messingrør       | Brass tube         | Messingrohr        | Tube de laiton       | Messingbuis         |
| F561        | 22         |                  |                 | Stolpe/naglebænk | Post/pin bench     | Sockel/nagelbank   | Socle/ratelier       | Sockel/nagelbank    |
| F565        | 1          |                  |                 | Wirerulle        | Wire reel          | Wire rolle         | Devidoir             | Katrol              |
| F567        | 1          |                  |                 | Bøjle            | Yoke               | Bügel              | Potence              | Beugel              |
| F577        | 4          |                  |                 | Pullert          | Bollard            | Poller             | Bitte                | Bolder              |
| F578        | 2          |                  |                 | Pullert/underlag | Bollard/support    | Poller/Unterlag    | Bitte/socle          | Bolder/console      |
| F663        | 1          | Ø0,75 x 9500mm   |                 | Messingtråd      | Brasswire          | Messingdraht       | Fil de laiton        | Messingdraad        |
| F664        | 255        |                  |                 | Øjebolt          | Eyebolt            | Augenbolzen        | Pitons               | Oogbouten           |
| F685        | 2          |                  |                 | Ventil/top       | Vent/top           | Lüfter/top         | Manche á air/tête    | Luchtkoker/top      |
| F686        | 2          |                  |                 | Ventil/sokkel    | Vent/tube          | Lüfter/rohr        | Manche á air/tube    | Luchtkoker/buis     |
| F689        | 2          |                  |                 | Kompas           | Compass            | Kompass            | Boussole             | Kompas              |
| F692        | 13         |                  |                 | Redningsflåde    | Liferaft           | Rettingsinsel      | Radeau de sauvetage  | Reddingsvlot        |
| F697        | 225        |                  |                 | Blok/enkelt      | Block/single       | Einzel block       | Poulie simple        | Eenschijfsblok      |
| F698        | 44         |                  |                 | Blok/dobbelt     | Block/double       | Doppel block       | Poulie double        | Tweeschijfsblok     |
| F741        | 1          |                  |                 | Plaststøb        | Plastic casting    | Plastikguss        | Fonte de plastique   | Kunststof           |
| F742        | 1          |                  |                 | Plaststøb        | Plastic casting    | Plastikguss        | Fonte de plastique   | Kunststof           |
| F743        | 190        |                  |                 | Øjebolt          | Eyebolt            | Augenbolzen        | Pitons               | Oogbouten           |
|             | 1          |                  |                 | Sejlstof         | Sailcloth          | Segelstoff         | Tissu de voile       | Zeildoek            |
|             | 1          |                  |                 | Net              | Net                | Netz               | Pochette plastique   | Net                 |
|             | 1          | TR 103           |                 | Transfers        | Transfers          | Abziehbilder       | Décalcomanies        | Transfers           |
|             | 1          |                  |                 | Flag             | Flag               | Flagge             | Drapeau              | Vlag                |
|             | 3          |                  |                 | Hovedtegninger   | Plan               | Zeichnungen        | Plans                | Bouwtekening        |
|             | 1          |                  |                 | Byggevejledning  | Building instr.    | Bauanleitung       | Instruction de mont. | Bouwbeschrijving    |

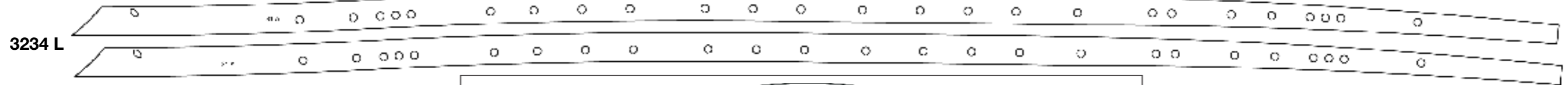
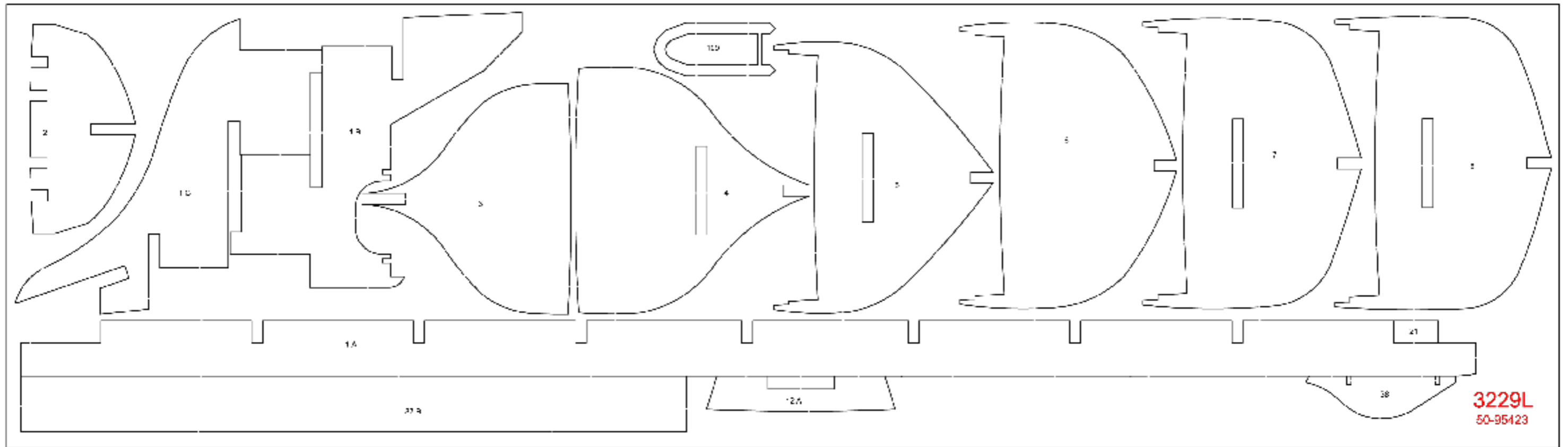

3237 L

SPECIAL  
EDITION



No.000

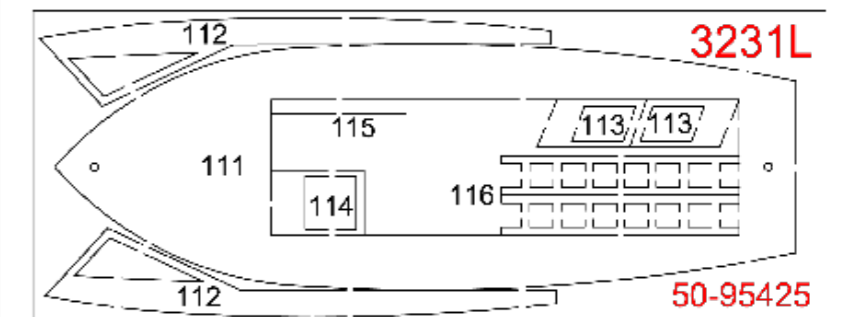
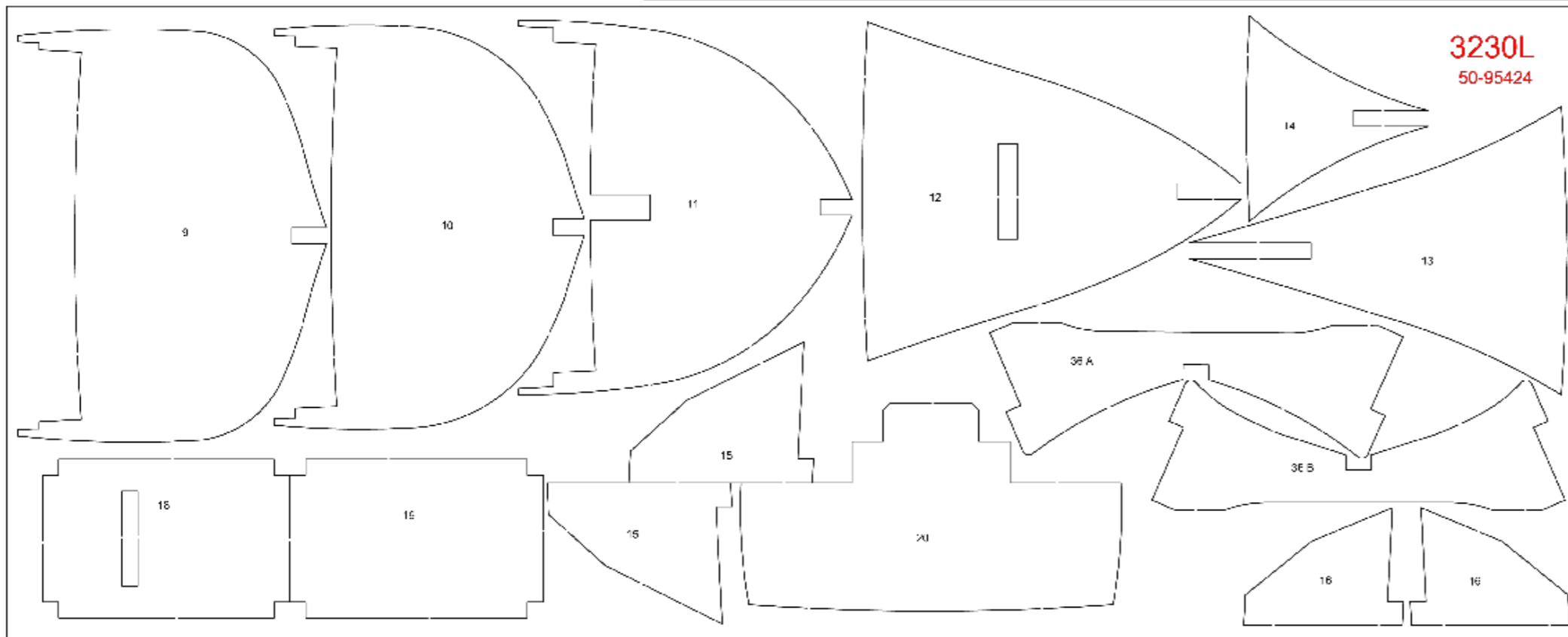



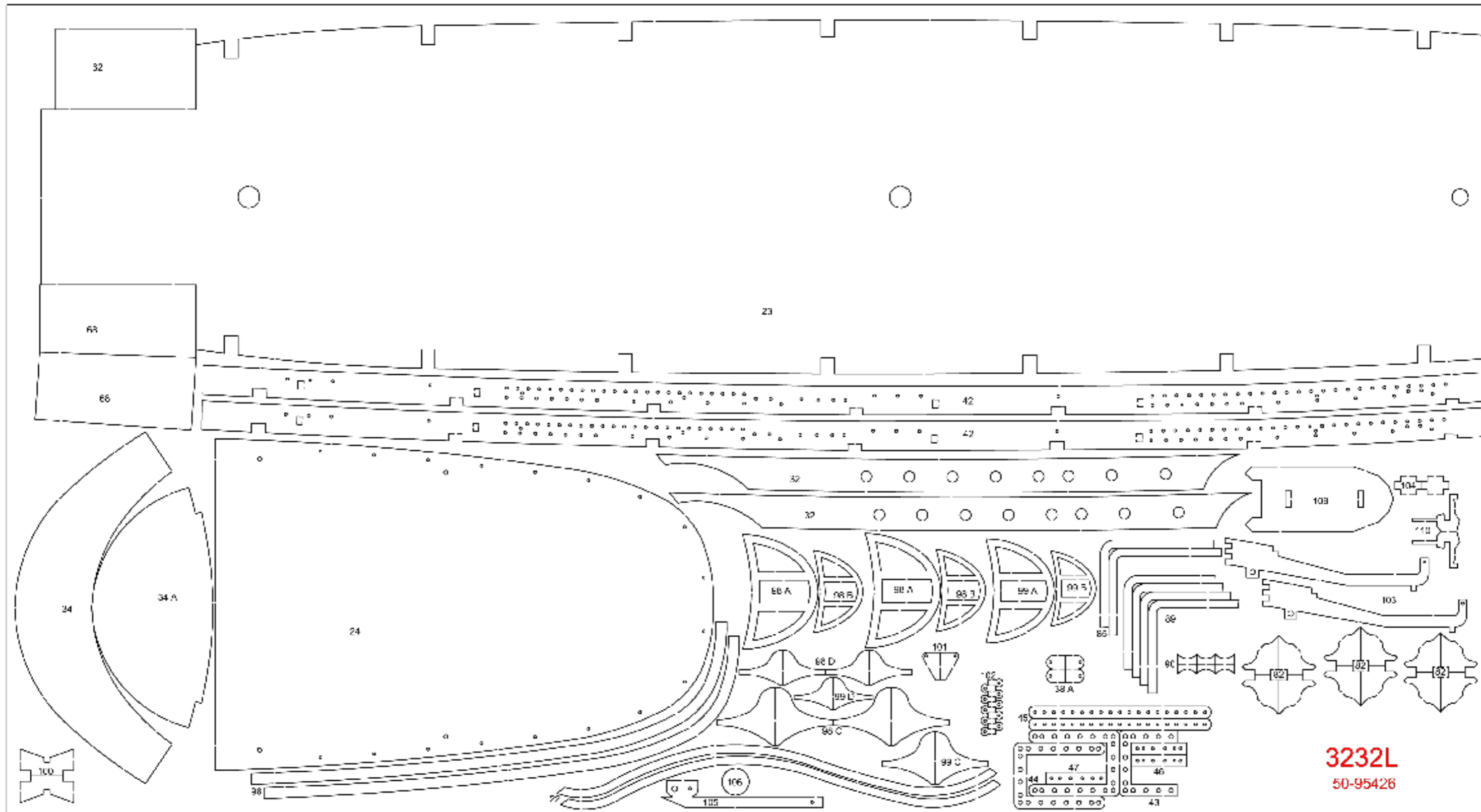

**3232L**  
 50-95426

**3235 L**

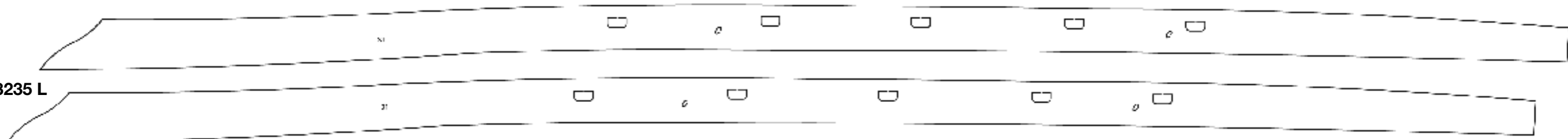

3233L  
50-95427



50-97110



**DANMARK**  
KØBENHAVN

DANMARK DANMARK DANMARK DANMARK DANMARK DANMARK

TR 103



DANMARK DANMARK

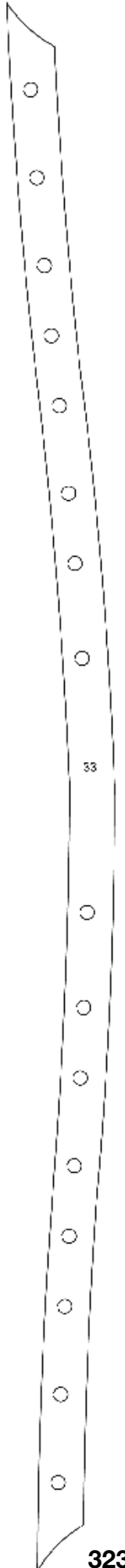

F 741

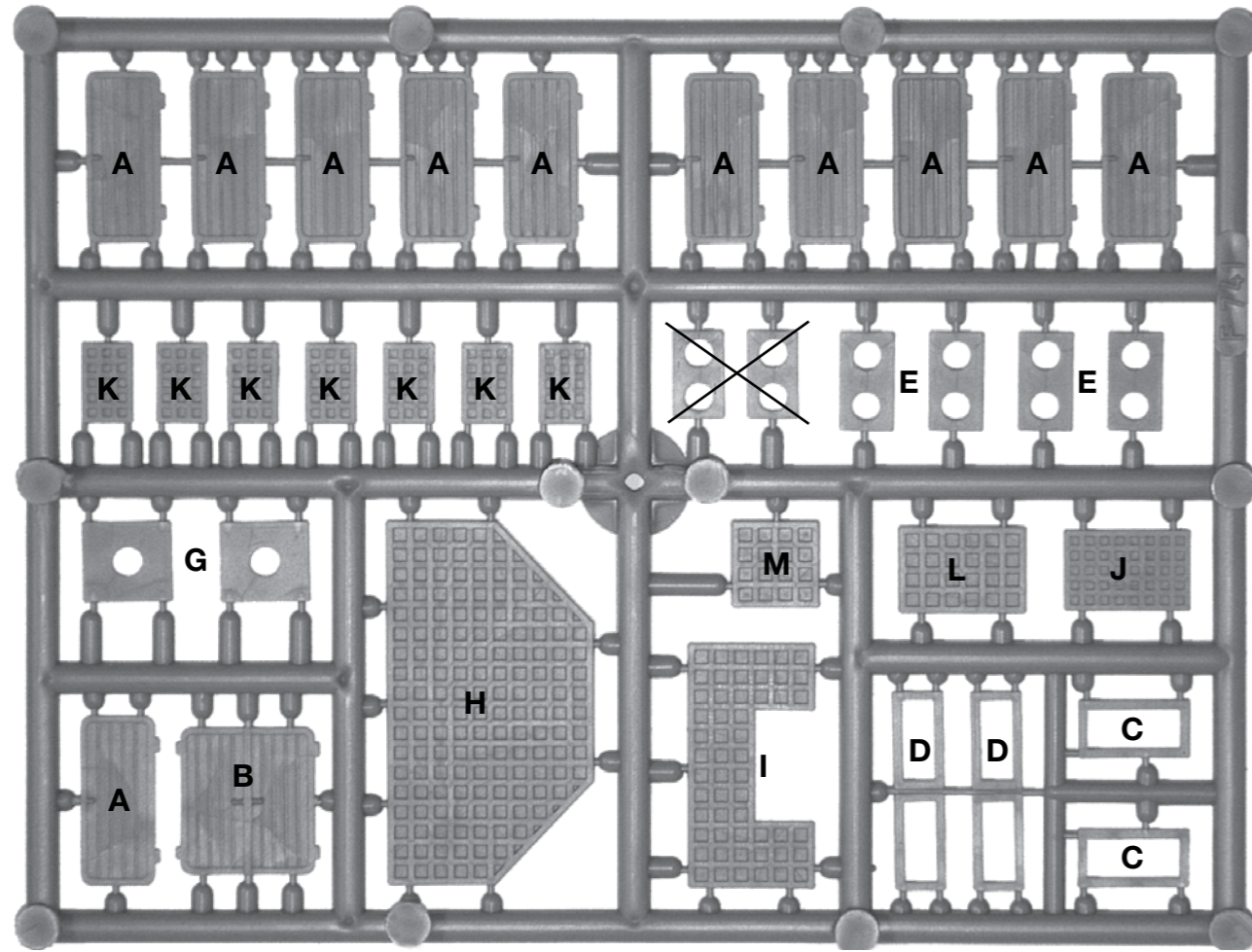

F 742

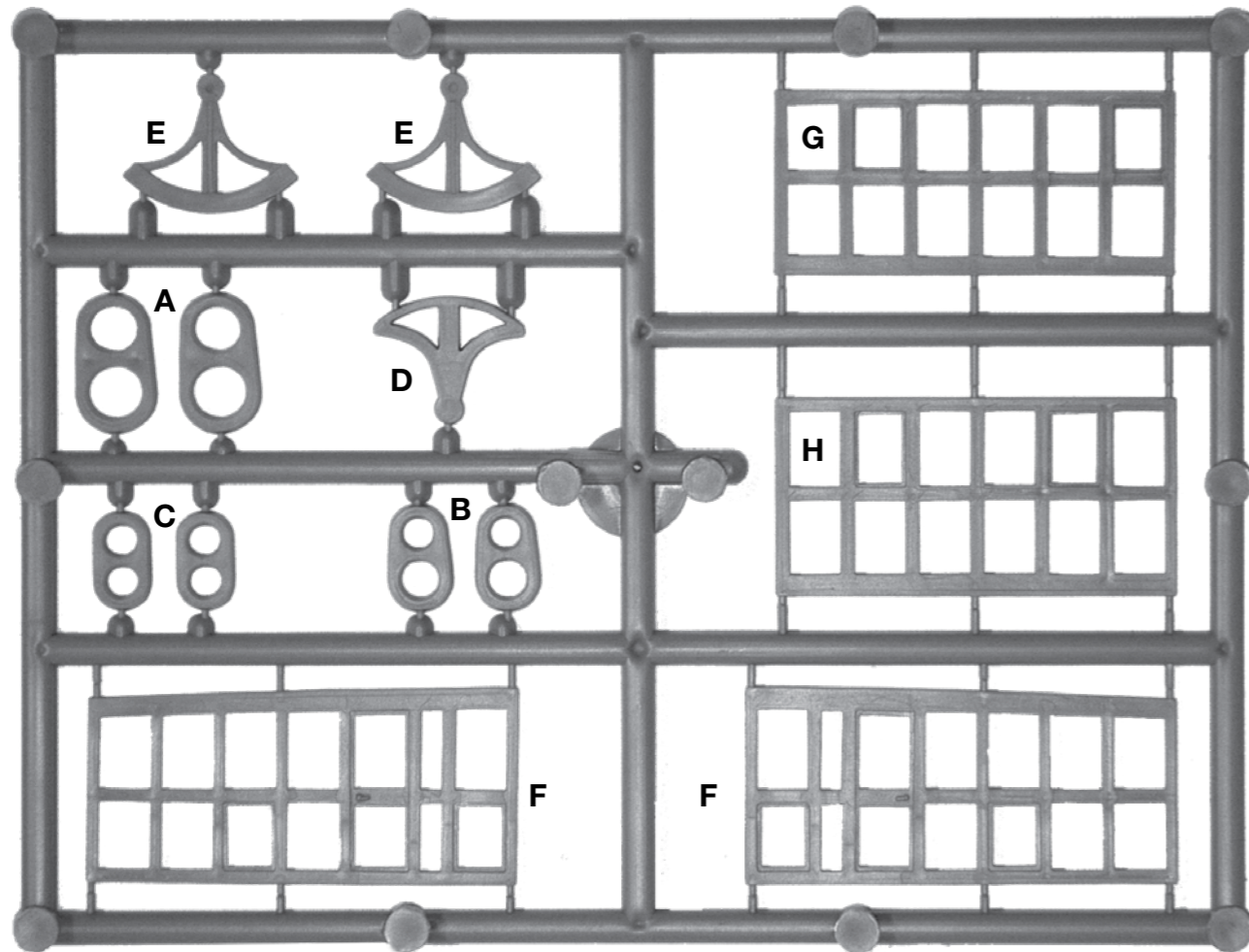

BB Glue Type



Plastic Glue



ABS Glue



Wood Glue



Cyano-Acrylate Glue



Epoxy Glue

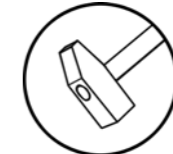

Use Hammer here



Cut in Length



Use File here



Drill



Use Knife here



Cut in Shape



Cut in Shape



Cut in Shape



Draw



Use Filler here



Do Not Glue

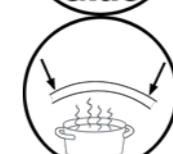

Shape over steam



Throw in Bin

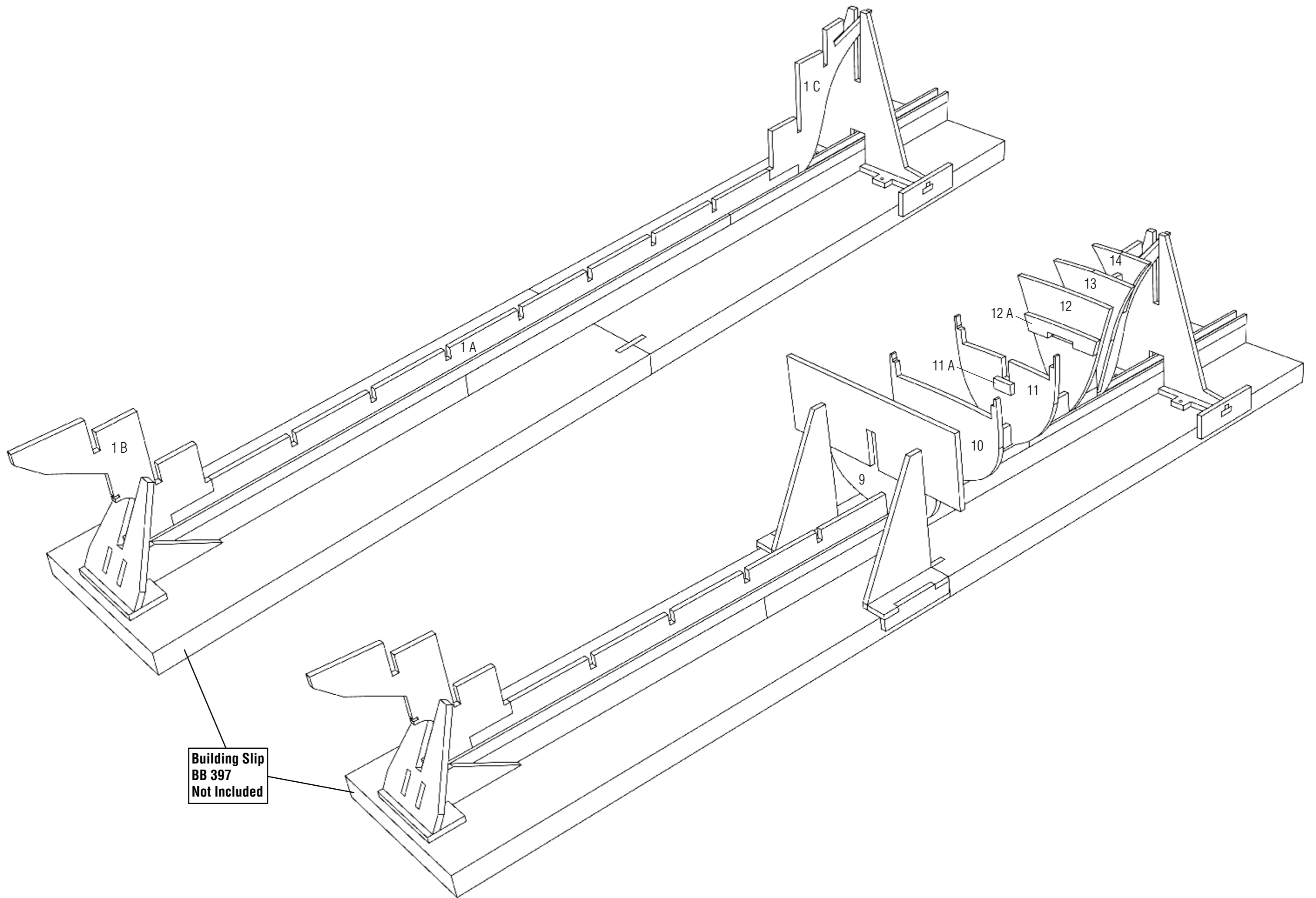

**Building Slip  
BB 397  
Not Included**

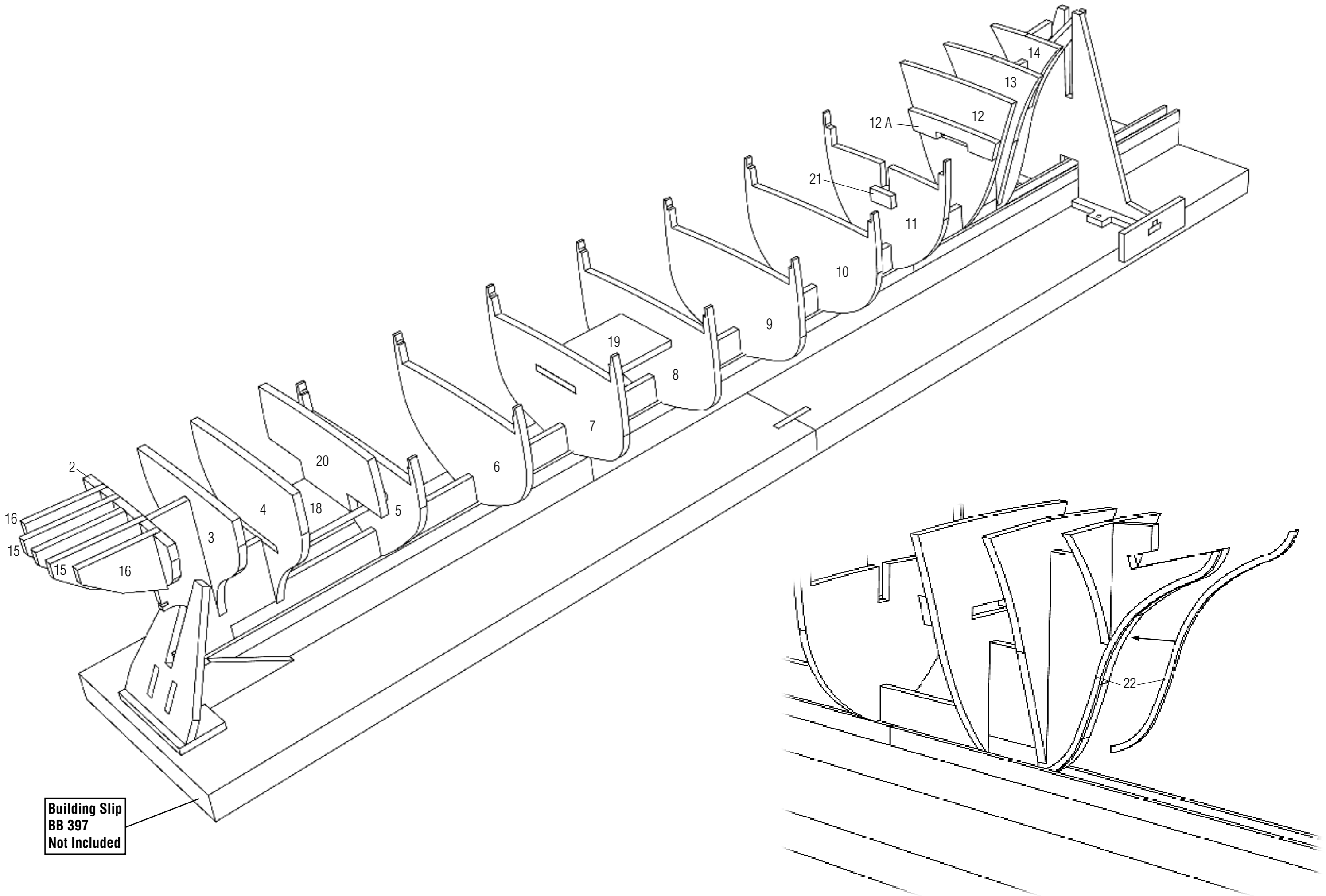

**Building Slip  
BB 397  
Not Included**

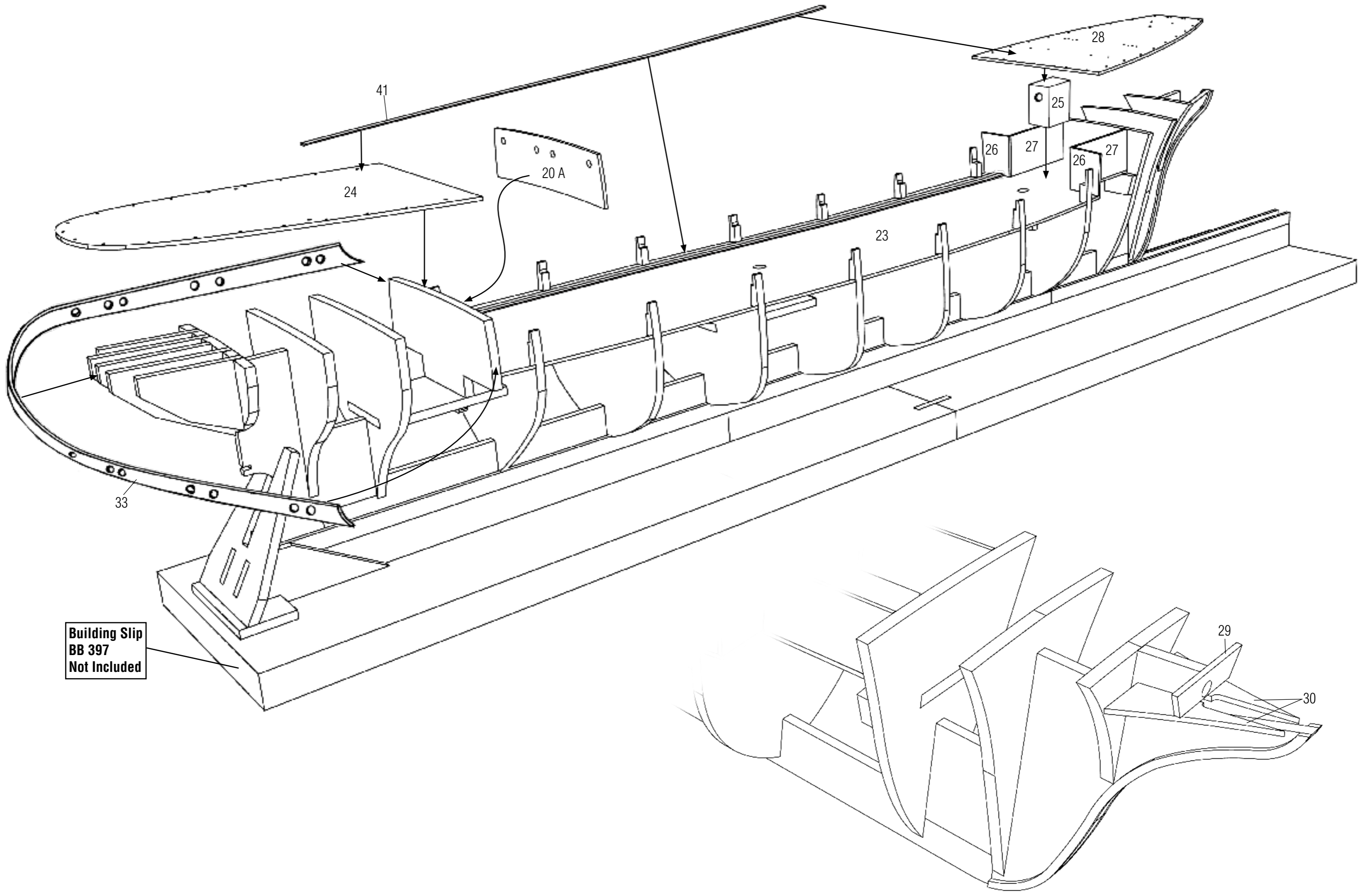

Building Slip  
BB 397  
Not Included

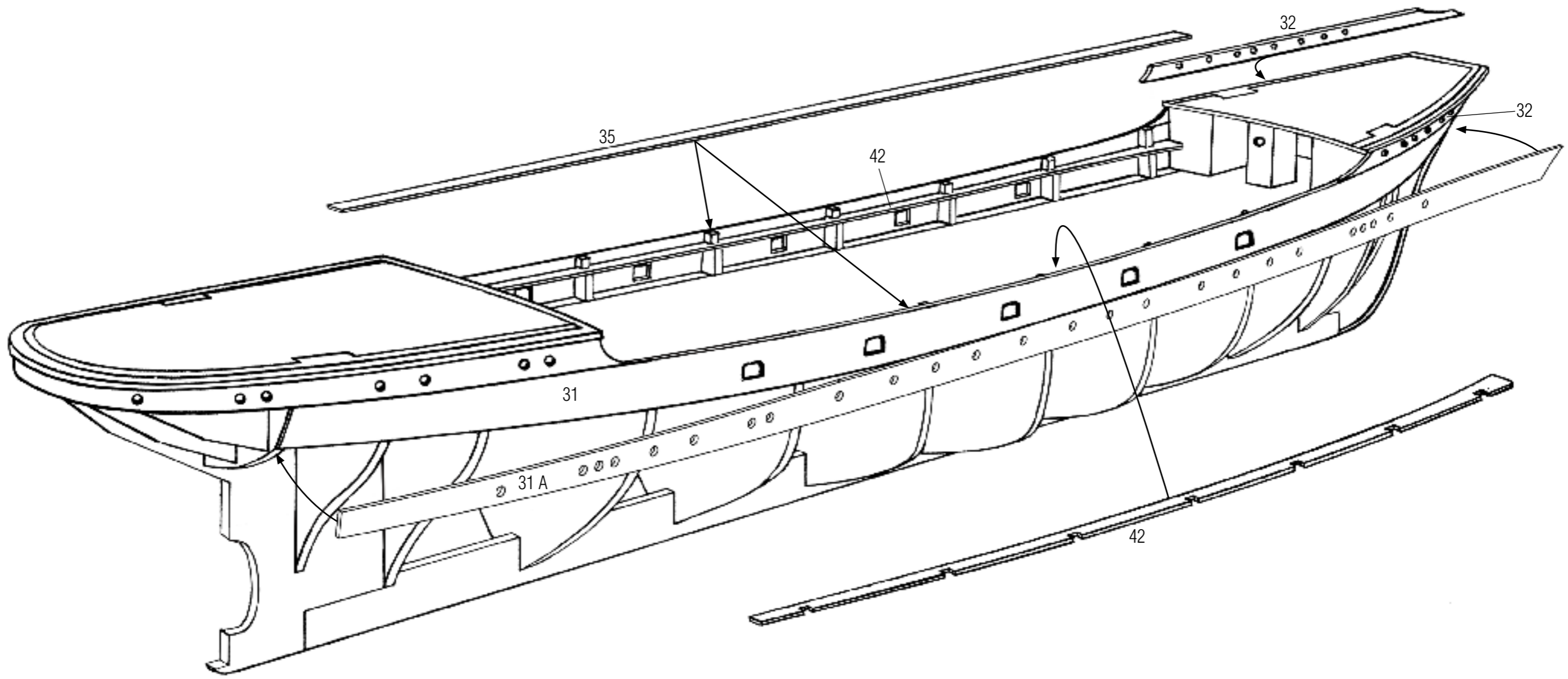

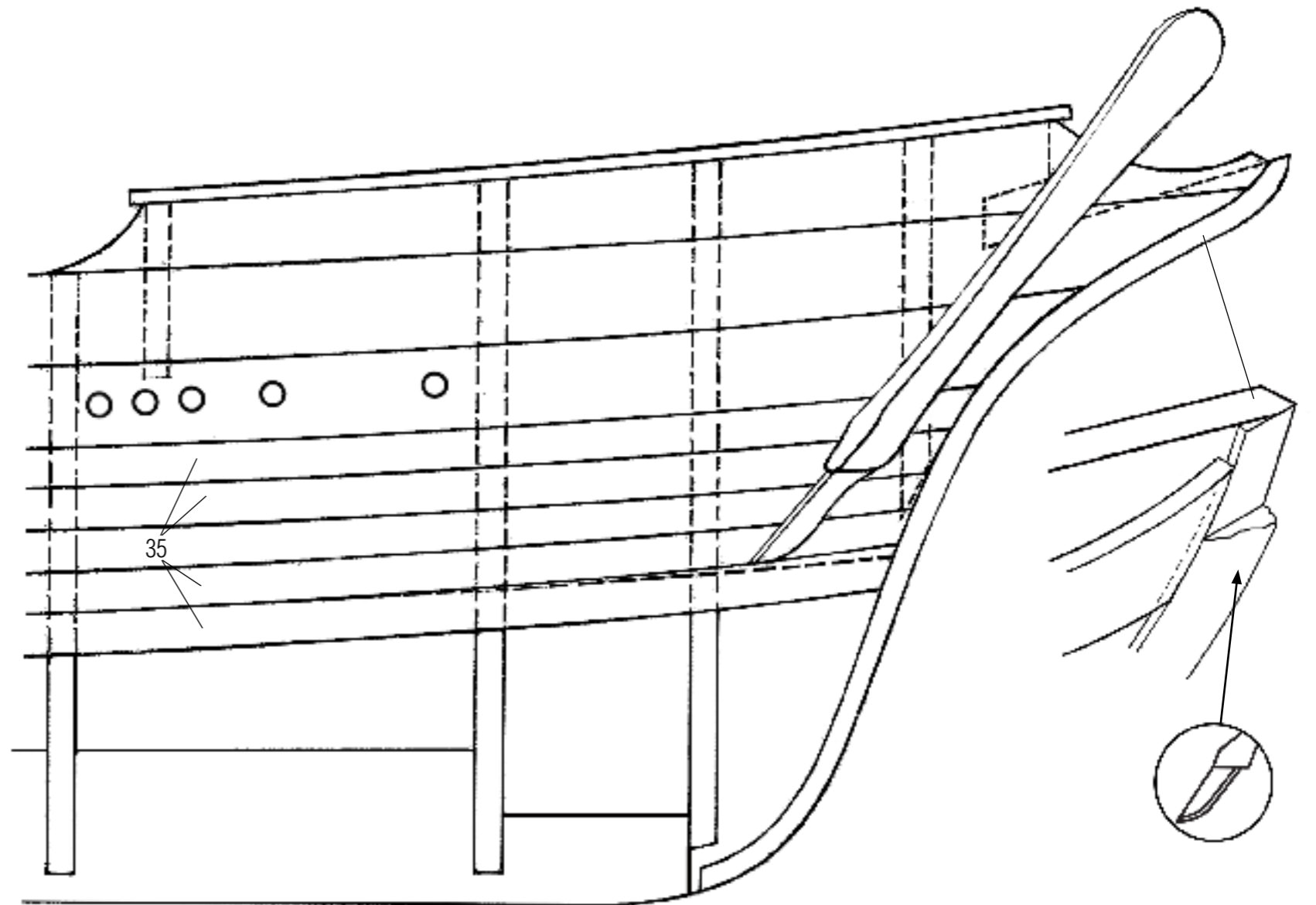
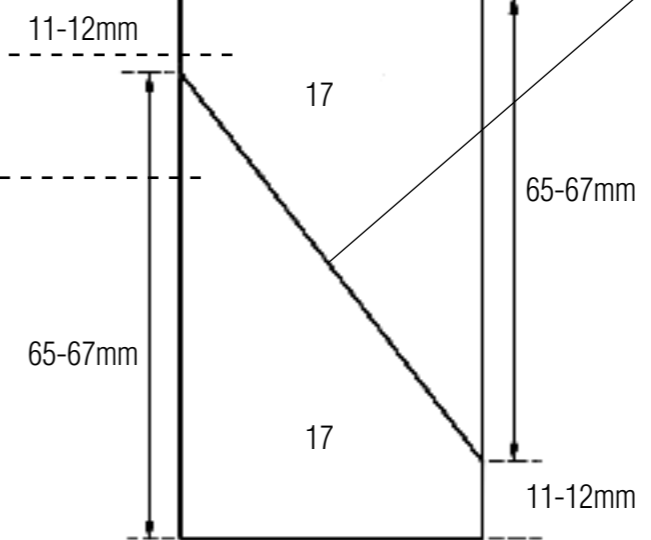
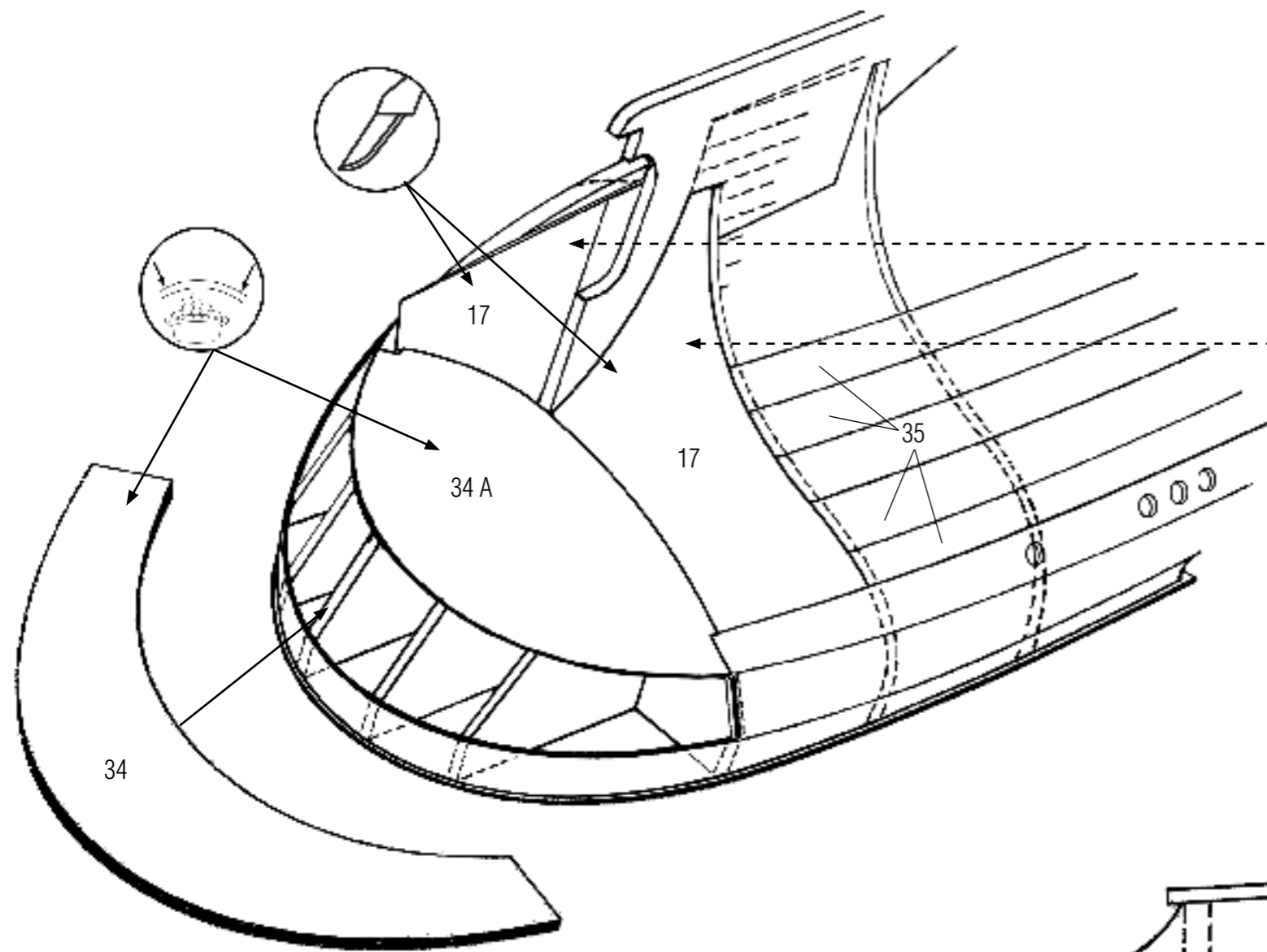



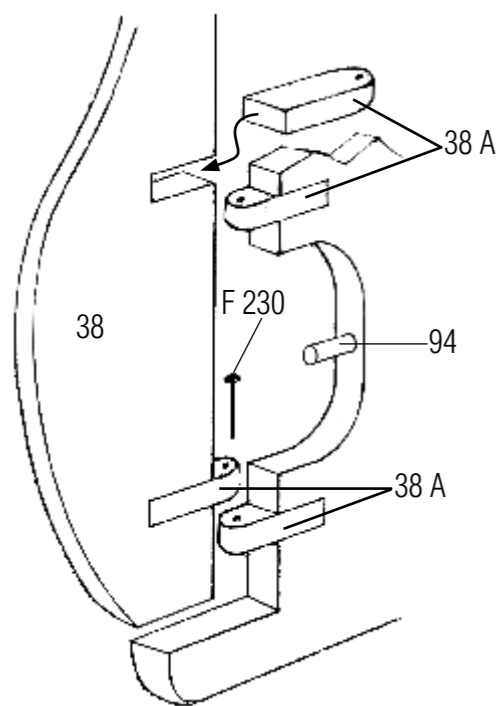
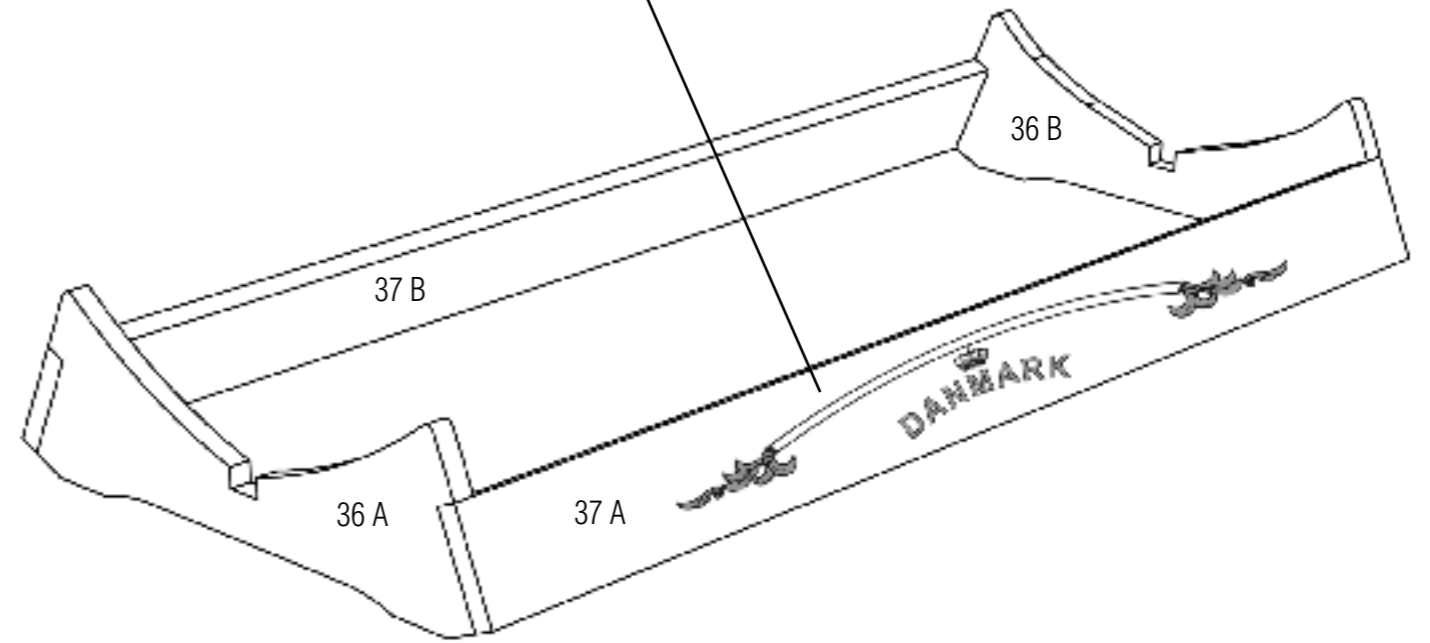
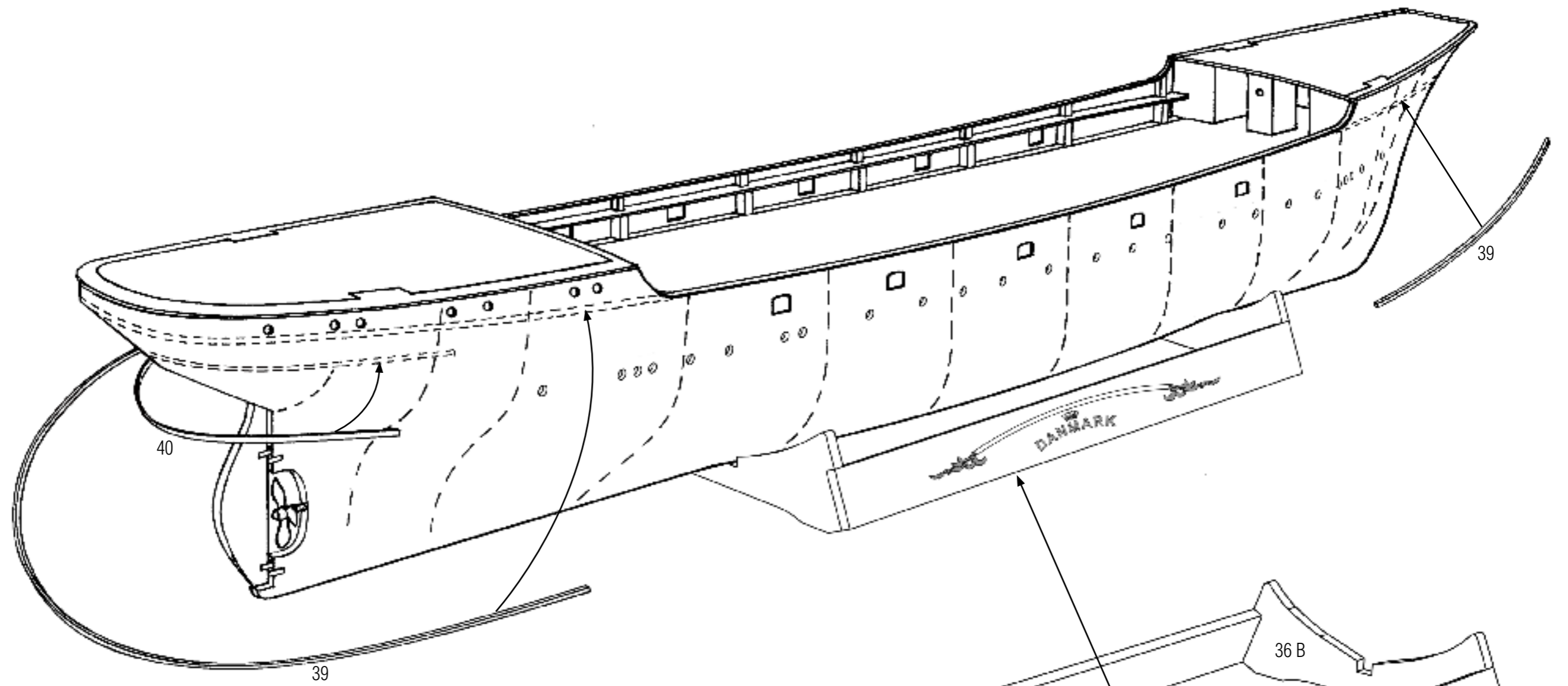

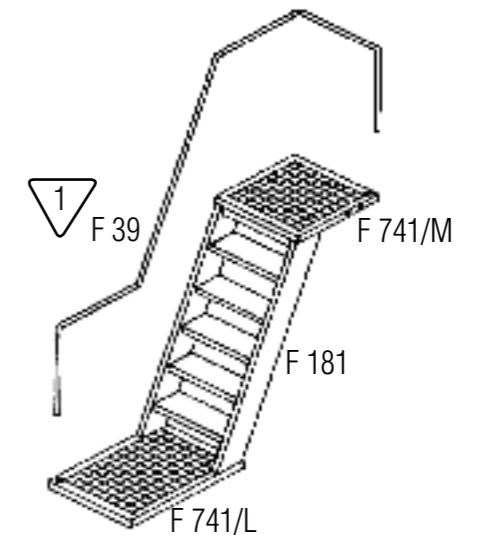
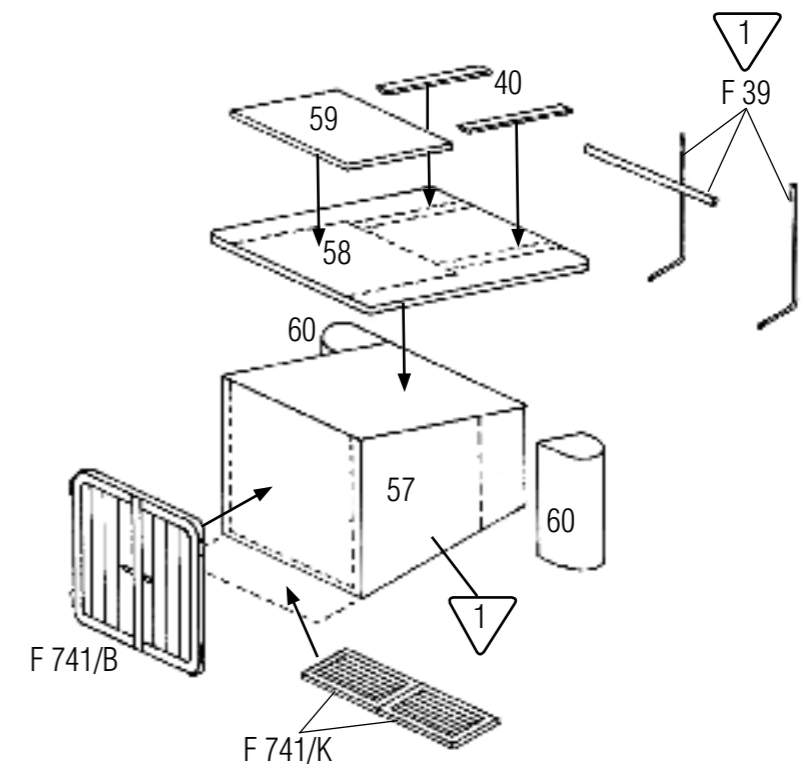
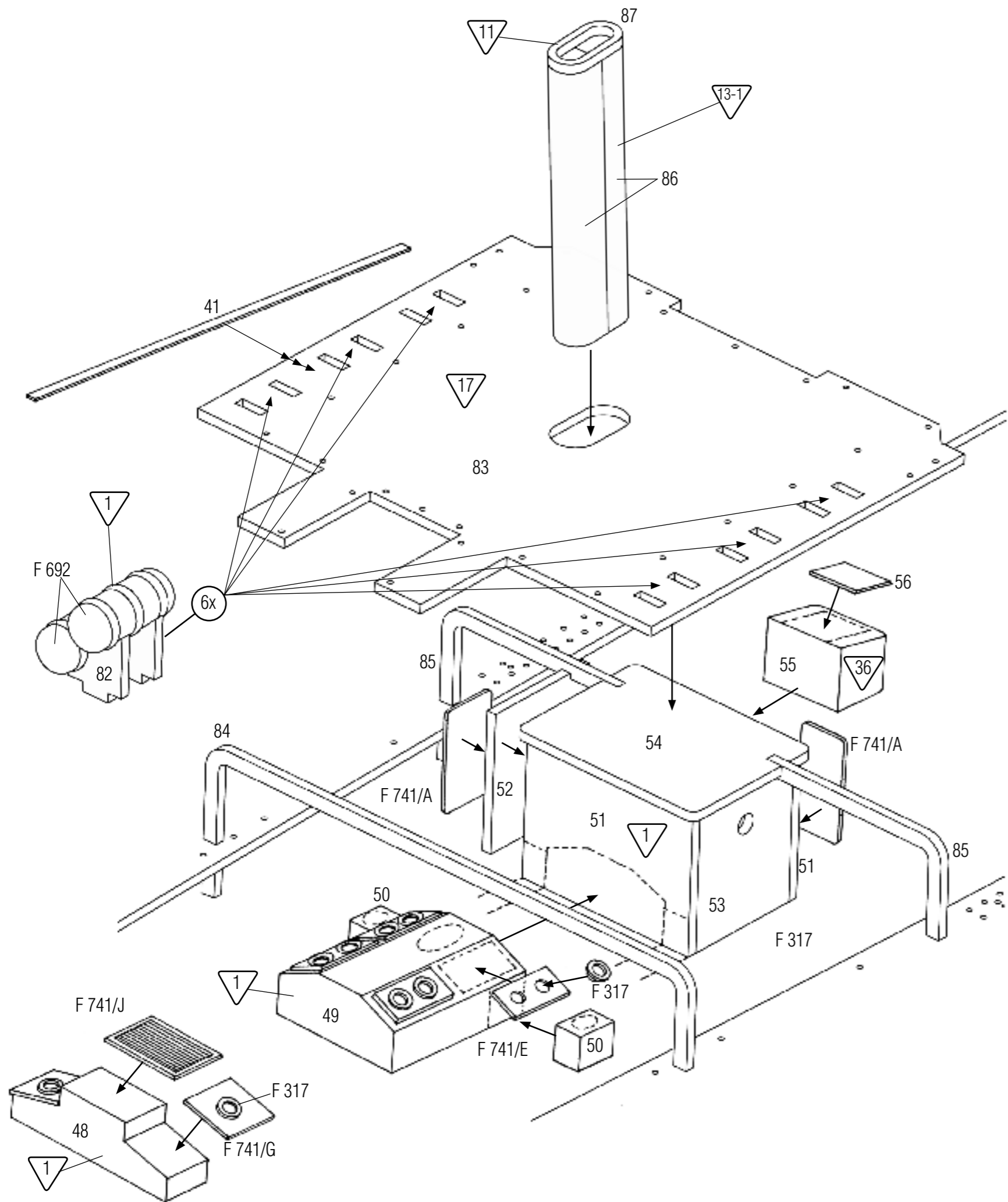

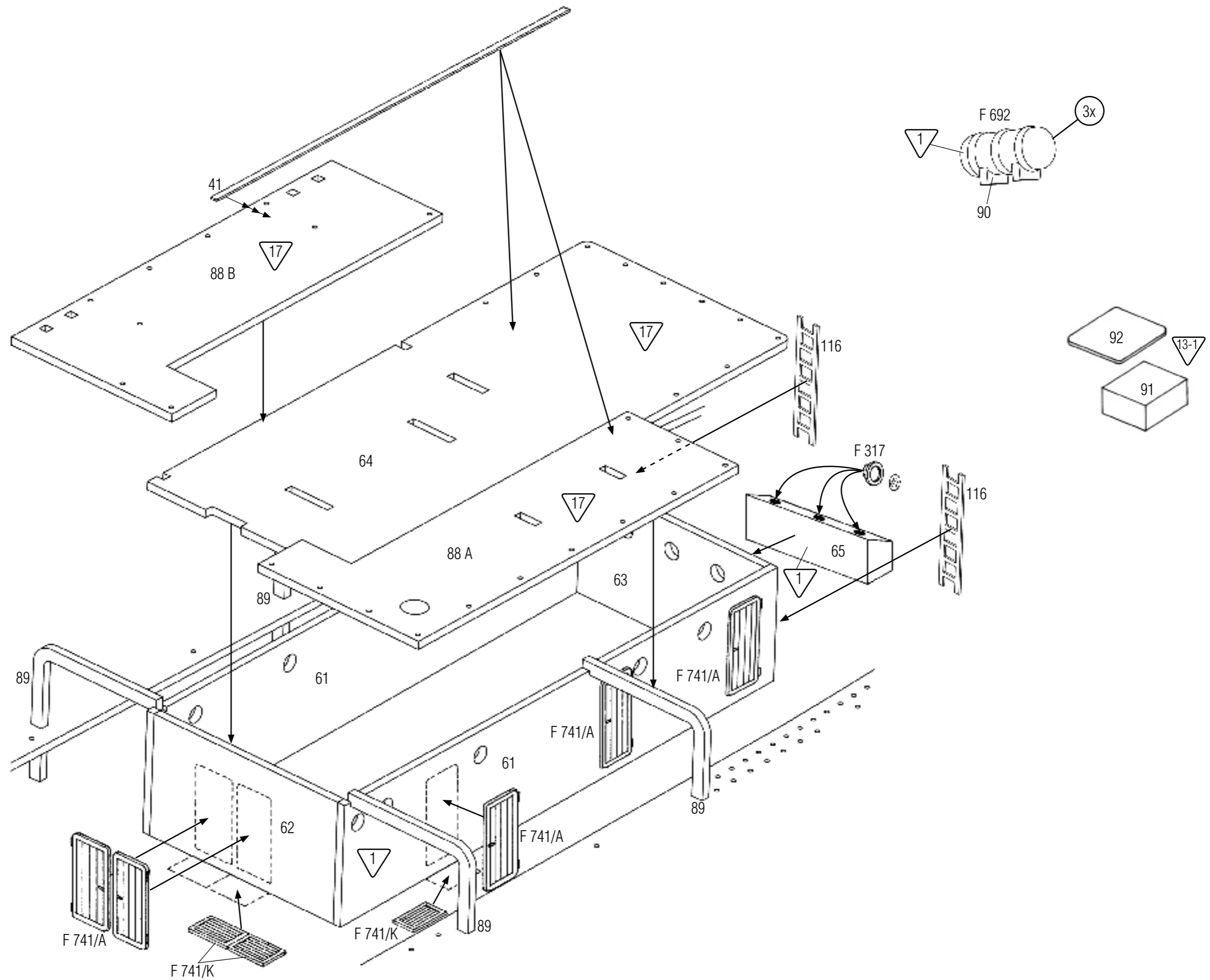

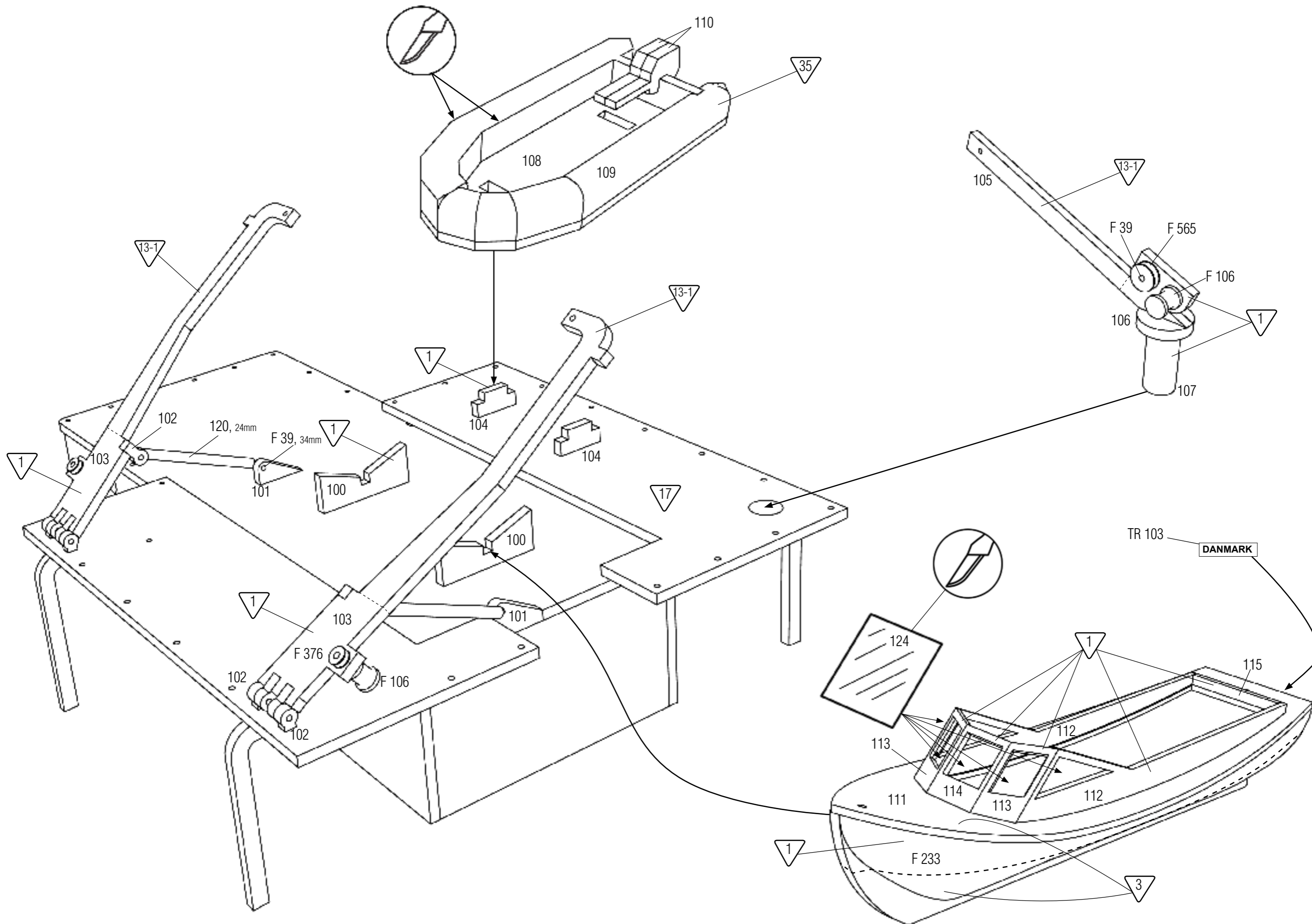

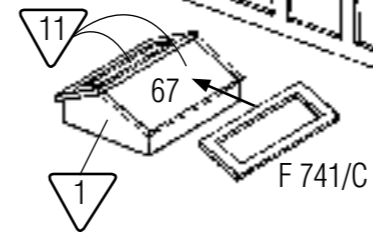
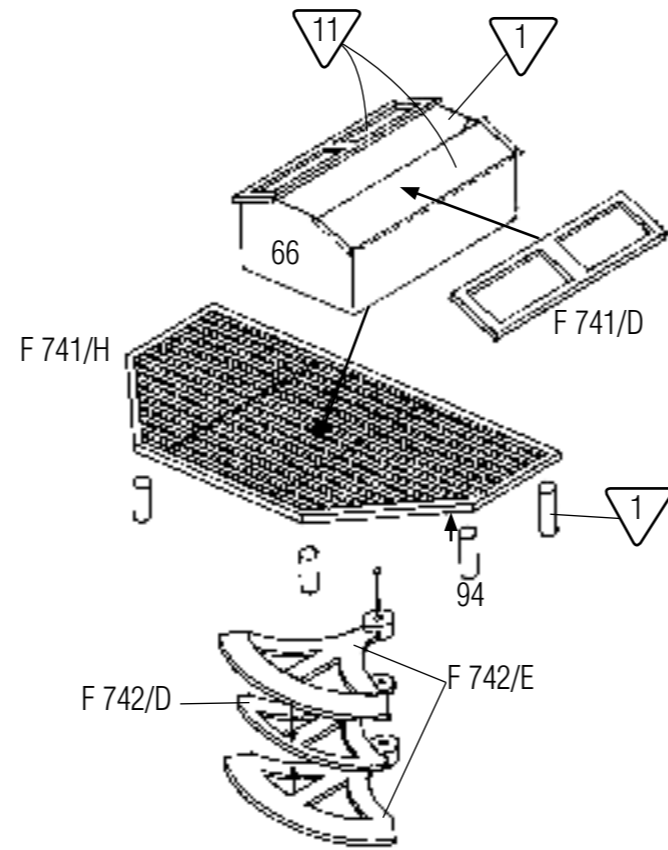
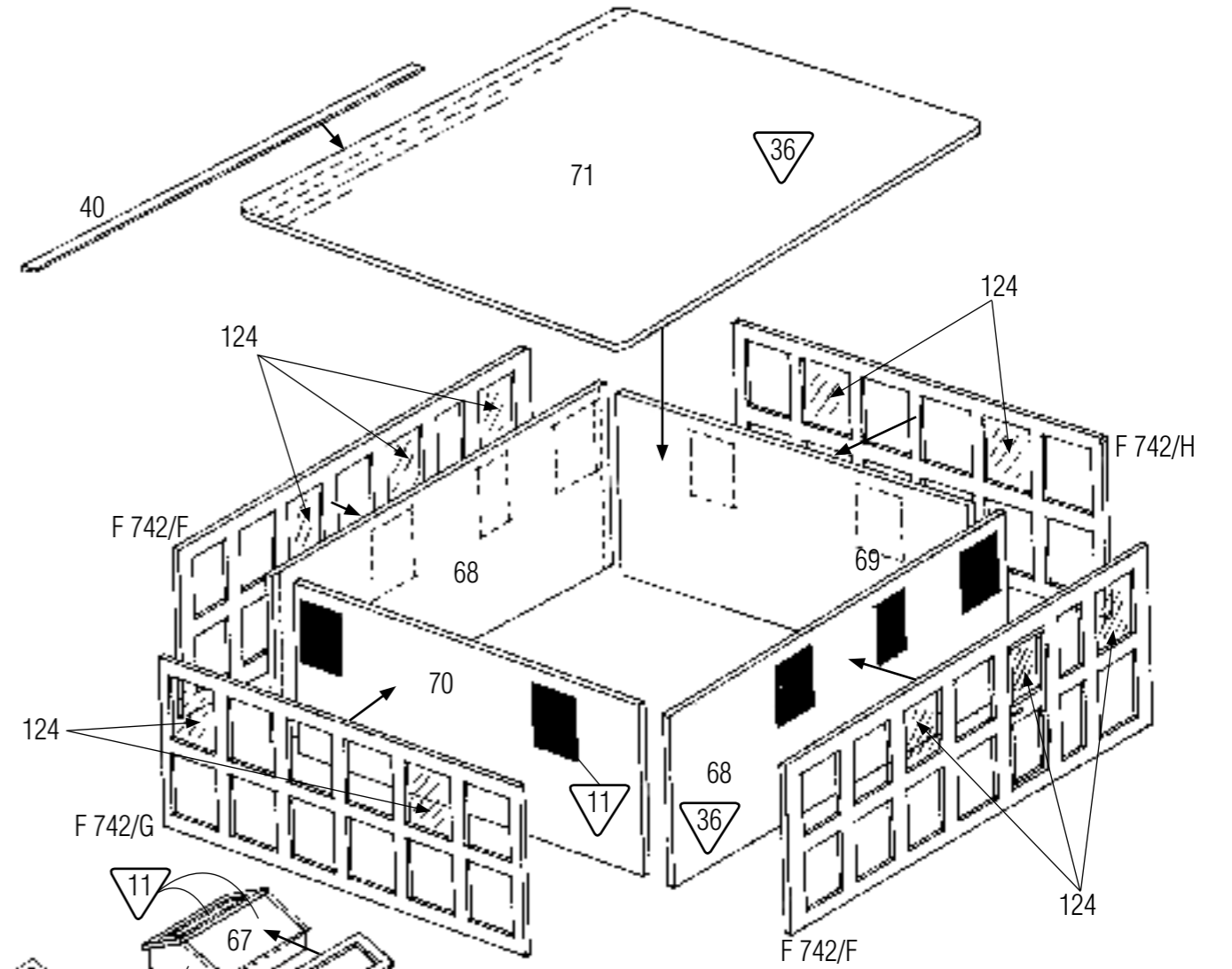
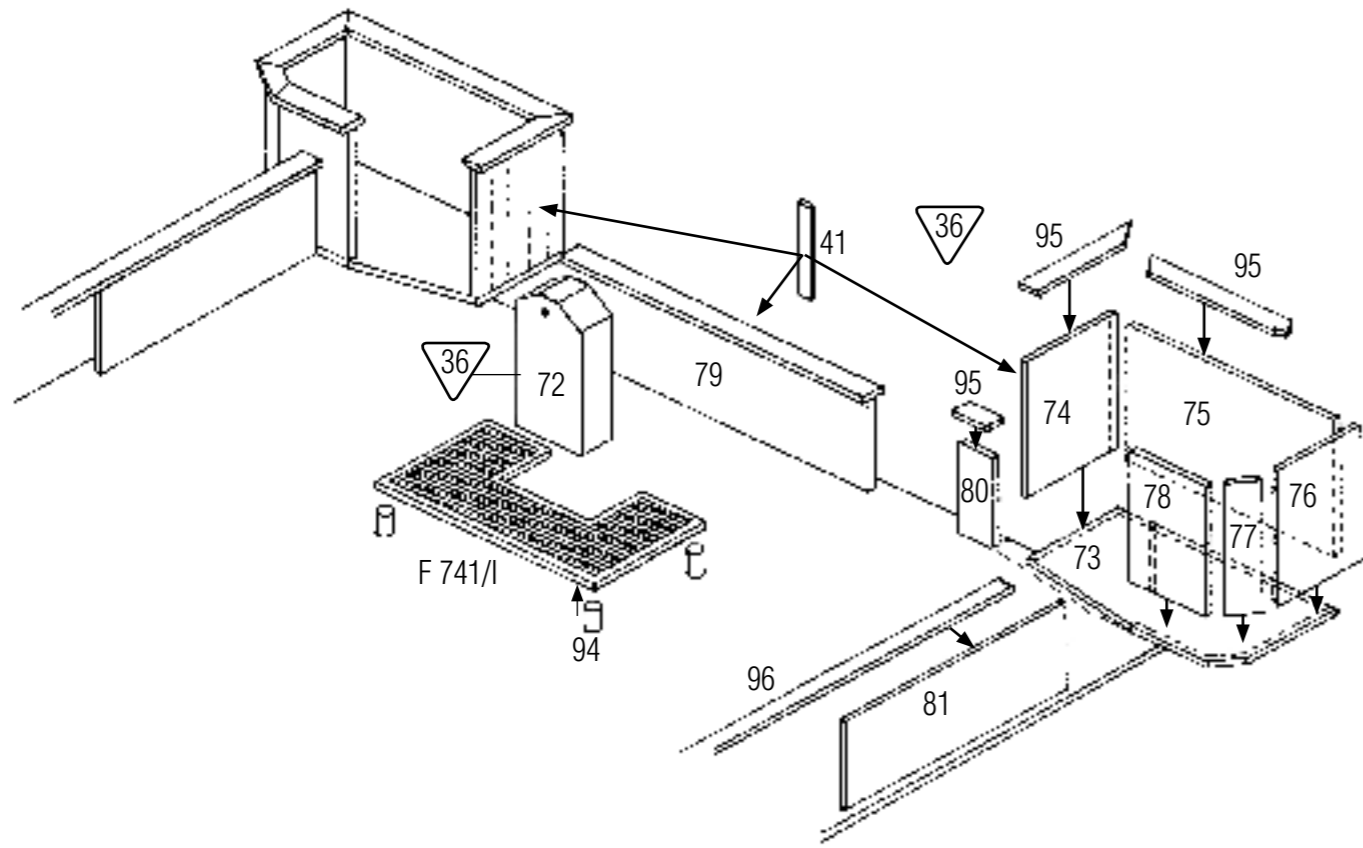

121

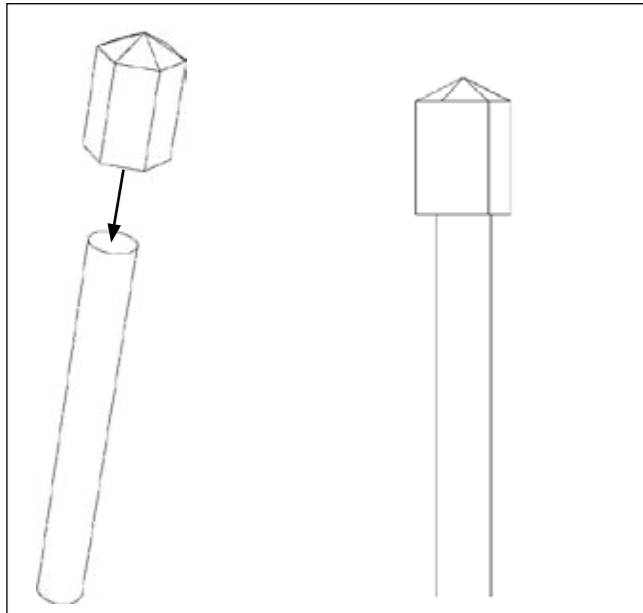

F 59

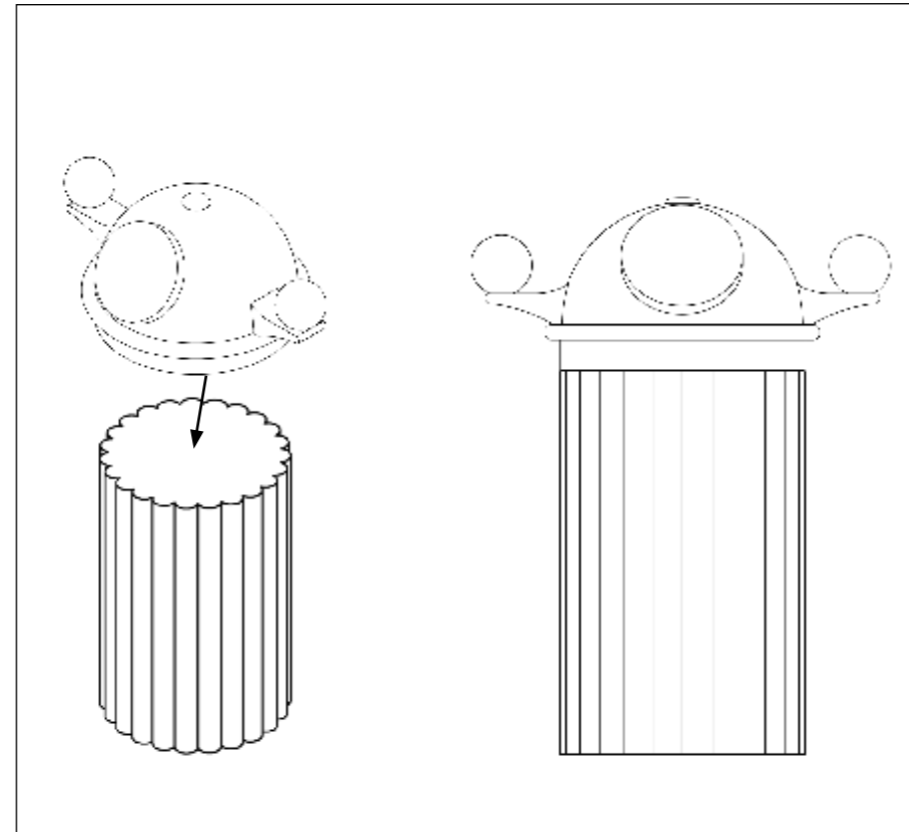

F 274

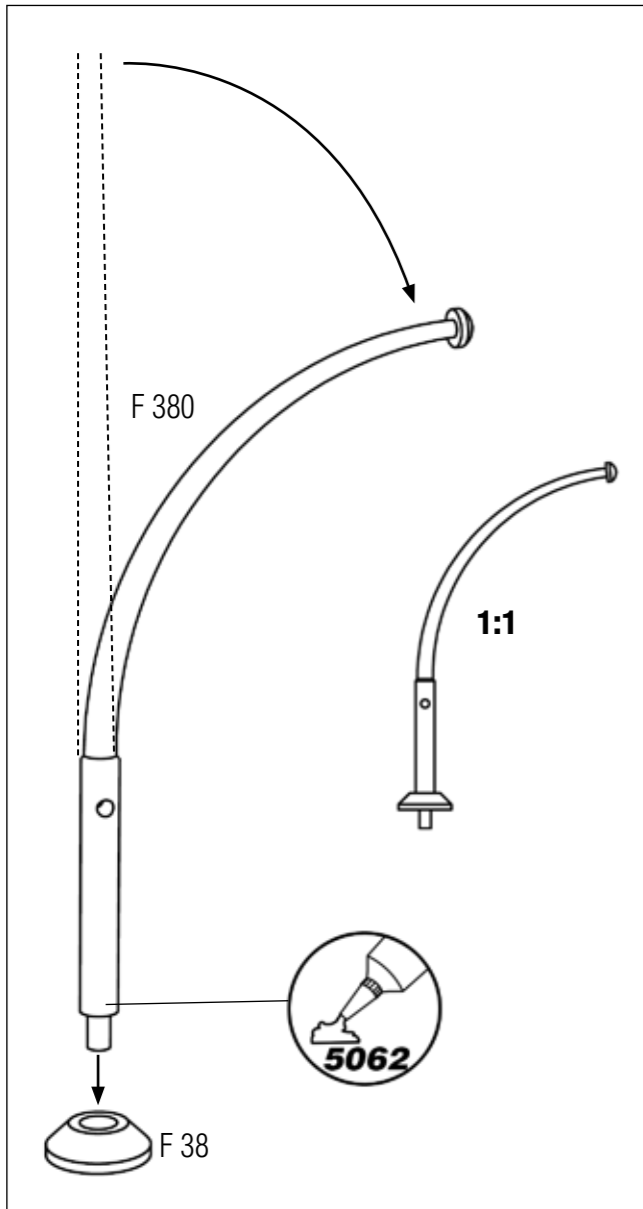
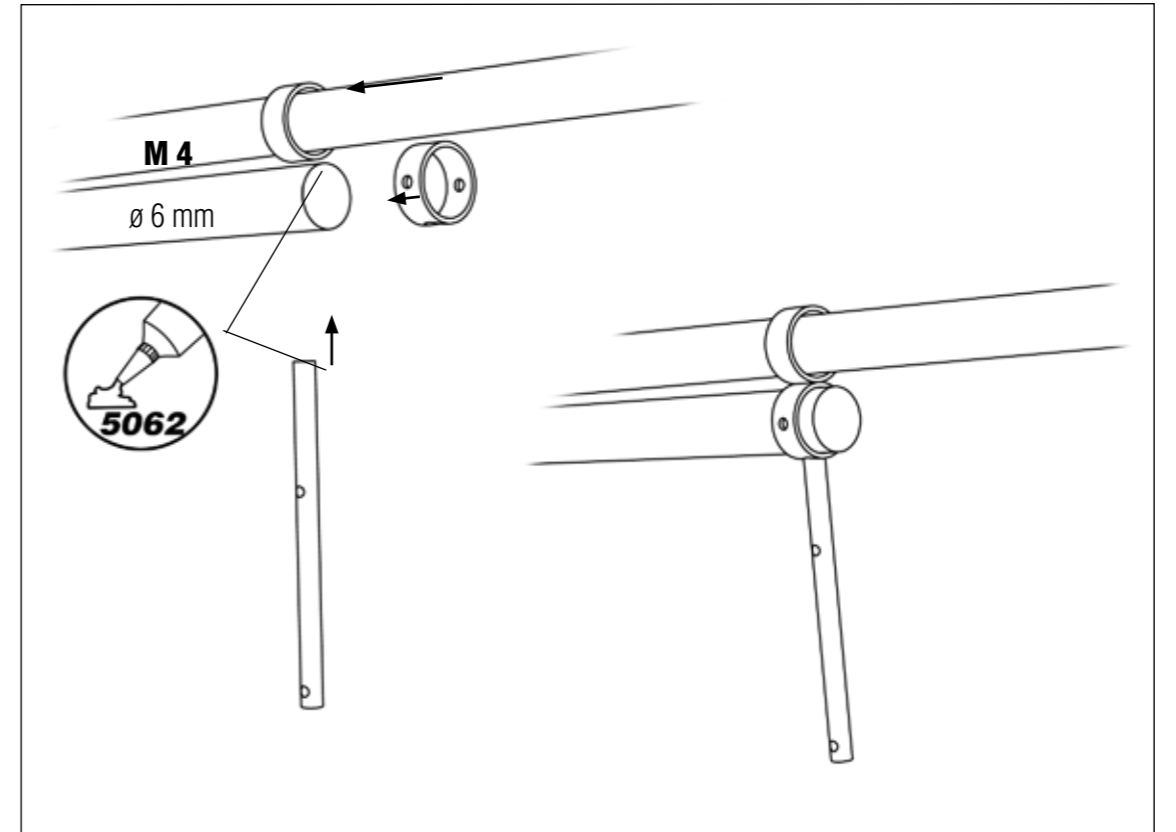

F 272

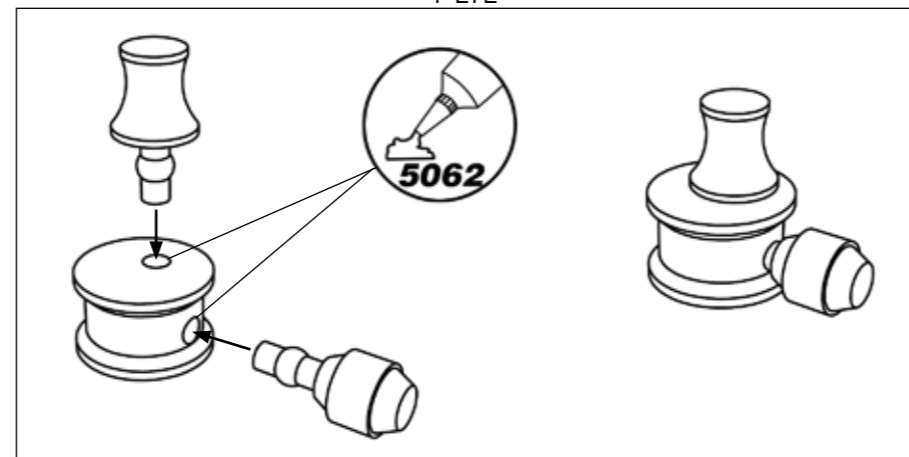

F 61

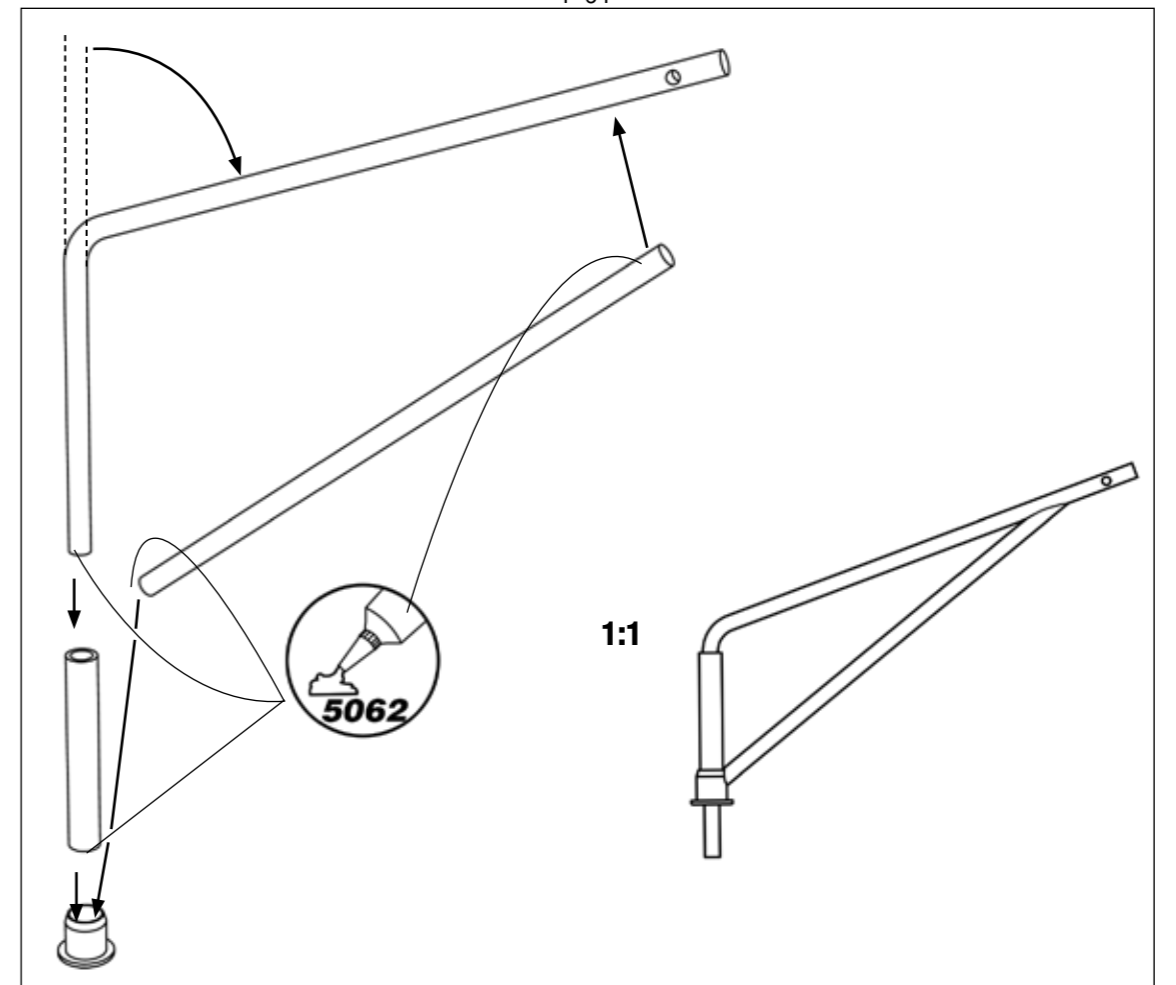

F 17

